



Features

- Low $R_{DS(on)}$ @ $V_{GS}=4.5V$
- 3.3V Logic Level Control
- N Channel SOT23 Package
- Pb-Free, RoHS Compliant

| $V_{(BR)DSS}$ | $R_{DS(ON)}$ Typ | I_D Max |
|---------------|---------------------|-----------|
| 20V | 48m Ω @ 4.5V | 2.3A |
| | 55m Ω @ 3.3V | |

Applications

- Load Switch for
- DC/DC Converter
- Switching Circuits
- LED Driver

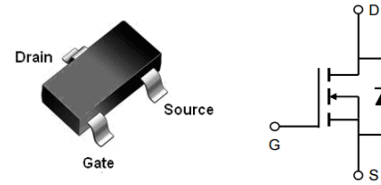

SOT-23

Order Information

| Product | Package | Marking | Packing | Min Unit Quantity |
|---------|---------|---------|--------------|-------------------|
| G2302S | SOT-23 | A2SHB | 3000PCS/Reel | 3000PCS |

Absolute Maximum Ratings

Stresses exceeding Maximum Ratings may damage the device. Maximum Ratings are stress ratings only. Functional operation above the Recommended Operating Conditions is not implied. Extended exposure to stresses above the Recommended Operating Conditions may affect device reliability.

| Symbol | Parameter | Rating | Unit |
|--|-------------------------------------|------------------------|--------------------|
| Common Ratings ($T_A=25^\circ\text{C}$ Unless Otherwise Noted) | | | |
| V_{GS} | Gate-Source Voltage | ± 10 | V |
| $V_{(BR)DSS}$ | Drain-Source Breakdown Voltage | 20 | V |
| T_J | Maximum Junction Temperature | 150 | $^\circ\text{C}$ |
| T_{STG} | Storage Temperature Range | -50 to 150 | $^\circ\text{C}$ |
| Mounted on Large Heat Sink | | | |
| I_{DM} | Pulse Drain Current Tested① | $T_A=25^\circ\text{C}$ | 9 A |
| I_D | Continuous Drain Current | $T_A=25^\circ\text{C}$ | 2.3 A |
| | | $T_A=70^\circ\text{C}$ | 1.8 A |
| P_D | Maximum Power Dissipation | $T_A=25^\circ\text{C}$ | 1 W |
| | | $T_A=70^\circ\text{C}$ | 0.8 W |
| $R_{\theta JA}$ | Thermal Resistance Junction-Ambient | 125 | $^\circ\text{C/W}$ |

| Symbol | Parameter | Condition | Min | Typ | Max | Unit |
|--|--|--|-----|------|------|------|
| Static Electrical Characteristics @ T_J = 25°C (unless otherwise stated) | | | | | | |
| V _{(BR)DSS} | Drain-Source Breakdown Voltage | V _{GS} =0V I _D =250μA | 20 | -- | -- | V |
| I _{DSS} | Zero Gate Voltage Drain Current(T _A =25°C) | V _{DS} =20V, V _{GS} =0V | -- | -- | 1 | μA |
| | Zero Gate Voltage Drain Current(T _A =125°C) | V _{DS} =16V, V _{GS} =0V | -- | -- | 100 | uA |
| I _{GSS} | Gate-Body Leakage Current | V _{GS} =±10V, V _{DS} =0V | -- | -- | ±100 | nA |
| V _{GS(TH)} | Gate Threshold Voltage | V _{DS} =V _{GS} , I _D =250μA | 0.4 | 0.6 | 1.0 | V |
| R _{DS(ON)} | Drain-Source On-State Resistance② | V _{GS} =4.5V, I _D =2A | -- | 48 | 60 | mΩ |
| R _{DS(ON)} | Drain-Source On-State Resistance② | V _{GS} =3.3V, I _D =1A | -- | 55 | 70 | mΩ |
| R _{DS(ON)} | Drain-Source On-State Resistance② | V _{GS} =2.5V, I _D =1A | -- | 66 | 80 | mΩ |
| Dynamic Electrical Characteristics @ T_J = 25°C (unless otherwise stated) | | | | | | |
| C _{iss} | Input Capacitance | V _{DS} =10V, V _{GS} =0V, f=1MHz | -- | 160 | -- | pF |
| C _{oss} | Output Capacitance | | -- | 30 | -- | pF |
| C _{riss} | Reverse Transfer Capacitance | | -- | 25 | -- | pF |
| Q _g | Total Gate Charge | V _{DS} =10V I _D =3A, V _{GS} =5V | -- | 4.0 | -- | nC |
| Q _{gs} | Gate Source Charge | | -- | 0.4 | -- | nC |
| Q _{gd} | Gate Drain Charge | | -- | 1.2 | -- | nC |
| Switching Characteristics | | | | | | |
| t _{d(on)} | Turn on Delay Time | V _{DD} =10V, I _D =2A, R _G =3.3Ω, V _{GS} =4.5V | -- | 8 | -- | ns |
| t _r | Turn on Rise Time | | -- | 30 | -- | ns |
| t _{d(off)} | Turn Off Delay Time | | - | 19 | -- | ns |
| t _f | Turn Off Fall Time | | -- | 28 | -- | ns |
| Source Drain Diode Characteristics | | | | | | |
| I _{SD} | Source drain current(Body Diode) | T _A =25°C | -- | -- | 1.5 | A |
| V _{SD} | Forward on voltage② | T _J =25°C, I _{SD} =1A, V _{GS} =0V | -- | 0.82 | 1.2 | V |

Notes:

① Pulse width limited by maximum allowable junction temperature



Typical Characteristics

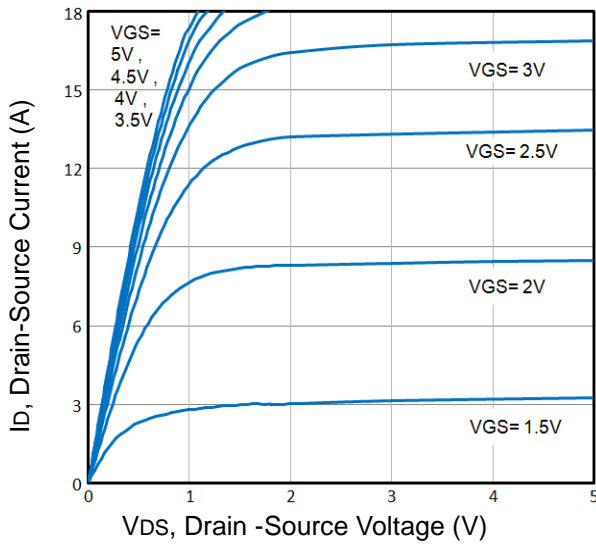

Fig1. Typical Output Characteristics

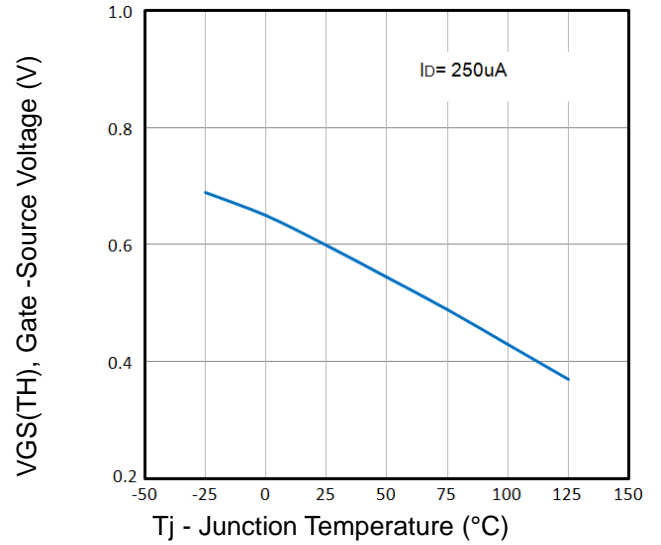

Fig2. Normalized Threshold Voltage Vs. Temperature

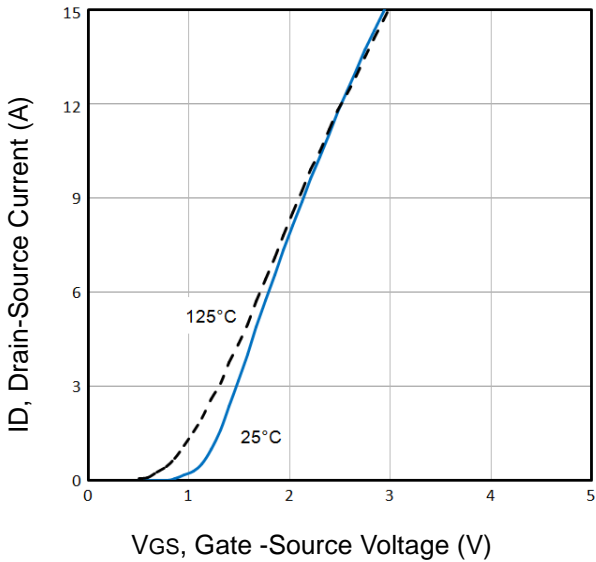

Fig3. Typical Transfer Characteristics

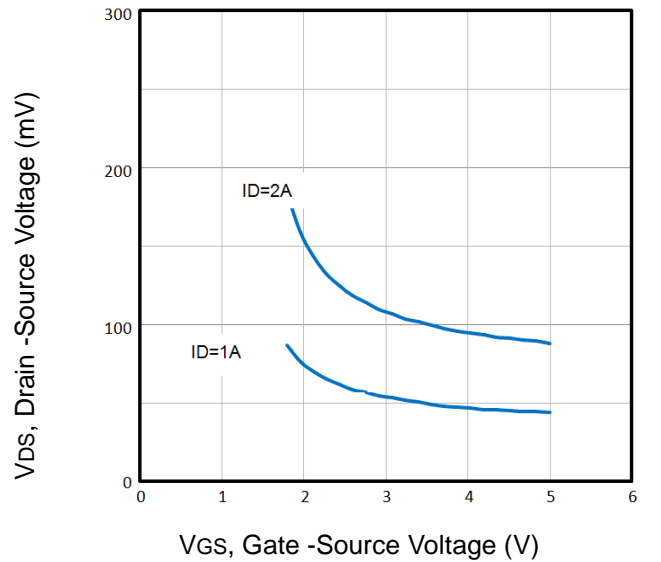

Fig4. Drain-Source Voltage vs Gate-Source Voltage

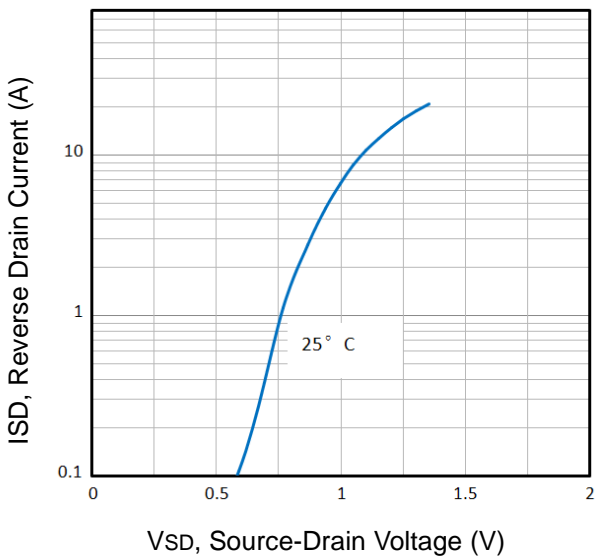

Fig5. Typical Source-Drain Diode Forward Voltage

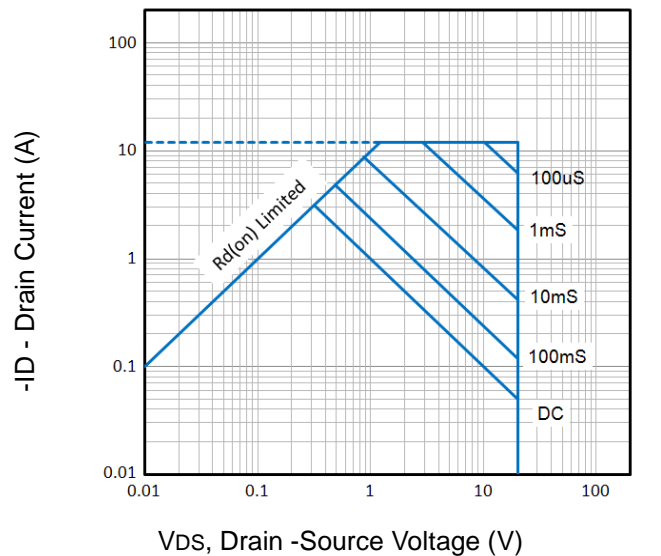

Fig6. Maximum Safe Operating Area



Typical Characteristics

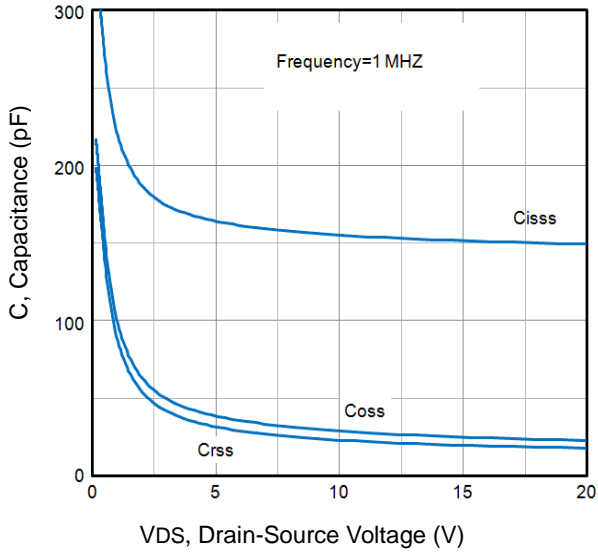

Fig7. Typical Capacitance Vs. Drain-Source Voltage

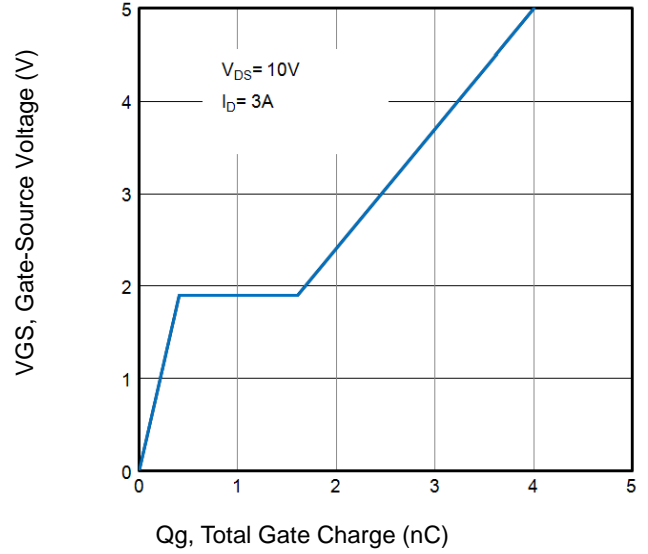

Fig8. Typical Gate Charge Vs. Gate-Source Voltage

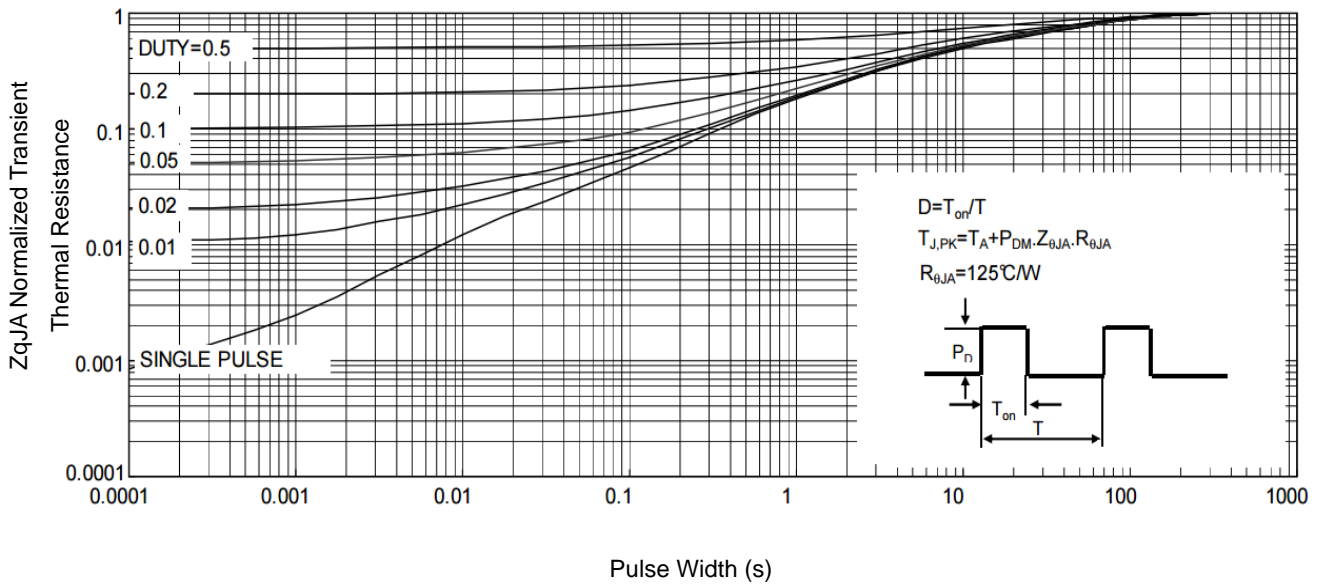

Fig9. Normalized Maximum Transient Thermal Impedance

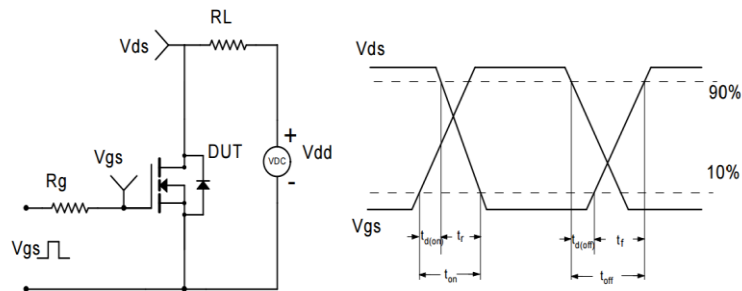
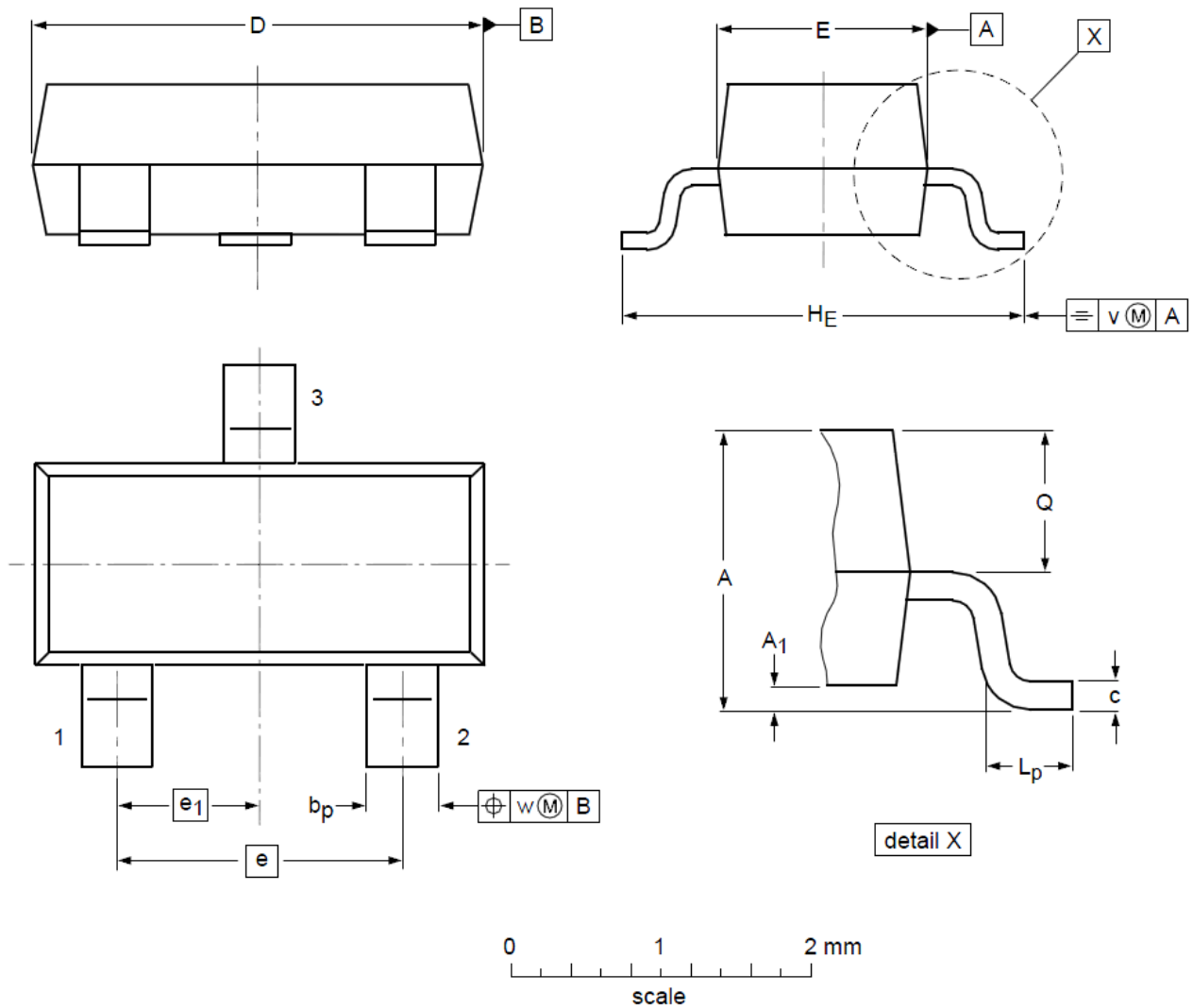

Fig10. Switching Time Test Circuit and waveforms

SOT23 Mechanical Data



DIMENSIONS (unit : mm)

| Symbol | Min | Typ | Max | Symbol | Min | Typ | Max |
|----------------|------|------|------|----------------|------|------|------|
| A | 0.90 | 1.01 | 1.15 | A ₁ | 0.01 | 0.05 | 0.10 |
| b _p | 0.30 | 0.42 | 0.50 | c | 0.08 | 0.13 | 0.15 |
| D | 2.80 | 2.92 | 3.00 | E | 1.20 | 1.33 | 1.40 |
| e | -- | 1.90 | -- | e ₁ | -- | 0.95 | -- |
| H _E | 2.25 | 2.40 | 2.55 | L _p | 0.30 | 0.42 | 0.50 |
| Q | 0.45 | 0.49 | 0.55 | v | -- | 0.20 | -- |
| w | -- | 0.10 | -- | | | | |