

獨石電容器規格承認書

APPROVAL SPECIFICATION FOR MONOLITHIC CAPACITORS

客戶
CUSTOMER

立創

客戶料號
CUSTOMER P/N

客戶規格描述
CUST. SPEC

規格描述
DESCRIPTION

100V/104/K/臥式/TB/環氧(黃)/X7R/0805

產品編碼
PART NUMBER

CD2A104K0DPHR1E000

日期
DATE

2024年4月15日

文件編號
DOC. NO.

DEC-SA-WI006

德爾創承認欄 APPROVED BY DERSONIC		客戶承認欄 APPROVED BY CUSTOMER		
批准 APPROVED BY	審核 CHECK BY	制訂 FORMULATE BY	批准 APPROVED BY	審核 CHECK BY
彭少雄	吳成愛 承認專用章	胡明康		

東莞市德爾創電子有限公司

DONGGUAN CITY DERSONIC ELECTRONIC CO., LTD.



廣東省東莞市寮步鎮松湖智谷產業園F2棟15樓
15/F, Blk F2, Songshan Lake Intelligent Valley Industrial Park,
Liaobu Town, Dongguan City, PRC
TEL: +86-769-8155 5686 FAX: +86-769-8155 5989
E-mail: sales@dersonic.com / quality@dersonic.com
Website: http://www.dersonic.com

獨石電容器規格承認書
APPROVAL SPECIFICATION FOR MONOLITHIC CAPACITORS

1. 規格表
DATA SHEET

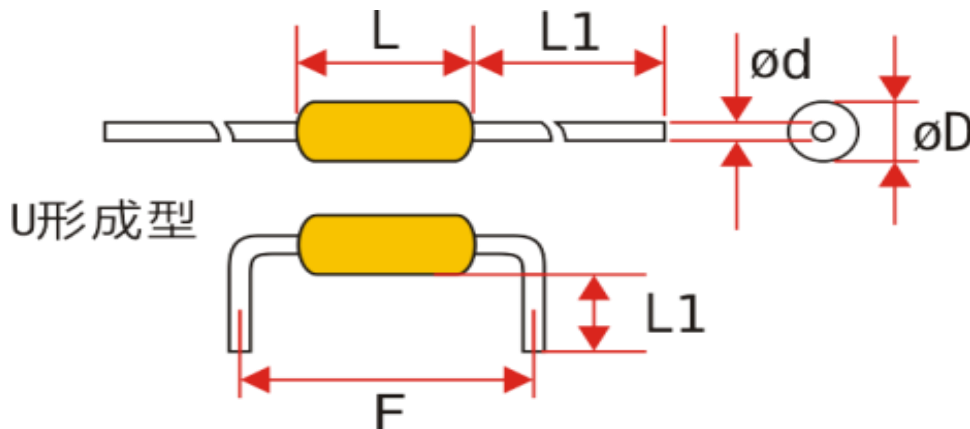

產品編碼 Part number	CD2A104K0DPHR1E000		
規格描述 Description	100V/104/K/臥式/TB/環氧(黃)/X7R/0805		
客戶料號 Customer P/N			
介質類別 Dielectric class	Class 2		
額定電壓 Rated voltage	100VDC		
電容量 Capacitance	0.1uF ±10% @ 1kHz 1V, 25°C		
損耗角正切 Tangent of loss angle	0.035 max @ 1kHz 1V 25°C		
耐電壓 Testing voltage	250V (Charge/discharge 50mA max), 3s, PASS		
絕緣電阻 Insulation resistance	1.5GΩ min @ 100V 60s, ≤RH70%		
溫度特性 Temperature characteristics	X7R ΔC/C: ±15% @ -55°C~125°C		
尺寸 DIMENSIONS	øD(Diameter)	3.0 mm max	
	L(Lenght)	4.60 mm max	
	L1(Lead Lenght)	---	
	F (Lead spacing)	---	
	P (Pitch of component)	5.0 mm±0.5mm	編帶尺寸規格見9頁 Taping specifications see P9
	ød (Lead diameter)	0.45 mm±0.10mm	
標誌 Marking	104		

2. 總則

GENERAL

1) 本規格書適用於電子設備用獨石電容器。
This specification applies to the leaded type MLCC for the electronic equipment.

2) 獨石電容器

Monolithic capacitor

獨石電容器是一種用積層陶瓷電容器焊接導線、並用環氧樹脂包封後的電容器。

Monolithic capacitor is a capacitor with a multilayer ceramic capacitor soldering lead wire and coating epoxy resin.

其具有以下特點：

It has the following characteristics :

■ 體積小，容量大，適合自動安裝的編帶包裝。

Miniature size, large capacitance, tape and reel packaging suitable for auto-placement.

■ 環氧樹脂封裝，從而具有優良的防潮性能、機械強度及耐熱性。

Epoxy resin coating creates excellent performance in humidity resistance, mechanical strength and heat resistance.

■ 工業生產標準尺寸及多種腳型產品。

Standard size, various lead configurations.

3) 符合RoHS 2.0

Complies with RoHS 2.0

3. 適用標準

APPLICABLE STANDARD

本產品符合下列標準，且本規格書的相關內容引用以下標準，當雙方對此存在爭議時，可依以下標準進行仲裁。

This product complies with the following standards, and the relevant content of this specification refers to the following standards, when the two sides in dispute, the following criteria for arbitration.

GB/T 2693-2001 電子設備用固定電容器 第1部分 總規範(IDT IEC 60384-1)

Fixed capacitors for use in electronic equipmen — Part 1: Generic specification (IDT IEC 60384-1)

GB/T 5966-2011 電子設備用固定電容器 第8部分 分規範 1類瓷介固定電容器(IDT IEC 60384-8)

Fixed capacitors for use in electronic equipmen — Part 8: Sectional specification: Fixed capacitors of ceramic dielectric, Class 1 (IDT IEC 60384-8)

GB/T 5968-2011 電子設備用固定電容器 第9部分 分規範 2類瓷介固定電容器(IDT IEC 60384-9)

Fixed capacitors for use in electronic equipmen — Part 9: Sectional specification: Fixed capacitors of ceramic dielectric, Class 2 (IDT IEC 60384-9)

獨石電容器規格承認書

APPROVAL SPECIFICATION FOR MONOLITHIC CAPACITORS

編號DOC NO.: DEC-SA-WI006

版本REV.: B/3

日期DATE: 2024年4月15日

頁碼PAGE: 3 / 9

4. 產品編碼

PART NUMBER

本公司產品編碼方式，舉例說明如下：

The product part number representation of the company, examples are as follows :

CD	2A	104	K	OD	P	H	R1	E	000
類別 Type	額定電壓 Rated voltage	標稱容量 Nominal capacitance	容量偏差 Capacitance tolerance	引線 成型方式 Lead format	編帶包裝 或散裝腳長 Taping packing or Lead length (bulk)	包封 Coating	溫度特性 Temperature characteristics	芯片 Chip spec	生產識別碼 Production identification code

■ 類別 Type

CD: 獨石電容器
Leads type MLCC

■ 額定電壓 Rated voltage

1H: 50V	3A: 1kV	1E: 25V	1J: 63V
2A: 100V	3D: 2kV	2E: 250V	2J: 630V
2H: 500V	3F: 3kV		

■ 標稱容量 Nominal capacitance

用3位數表示，單位pF。如下所示：
In 3 digits, unit is pF, as shown in below:
104: 0.1uF (1uF = 1,000nF = 1,000,000pF)

■ 容量偏差 Capacitance tolerance

C: ±0.25pF	J: ±5%	S: +50%/-20%
D: ±0.50pF	K: ±10%	Z: +80%/-20%
	M: ±20%	P: +100%/-0%

■ 引線成型方式 Lead format

代碼 Code	腳距 Lead spacing
A	2.54mm
B	3.5mm
C	5.08mm
D	7.50mm
0	臥式Axial

代碼 Code	1	0	9	D
腳型樣式 Lead style drawing				

■ 編帶包裝或散裝腳長 Taping packing or Lead length (bulk)

● Taping
T: Reel packing
P: Ammo packing

● Bulk (Leads length)

4: 3.5mm	A: 8.0mm	V: 7.0mm
6: 4.0mm	B: 10.0mm	Q: 9.0mm
8: 5.0mm	I: 24.0mm	C: 12.0mm
9: 6.0mm		2: 3.0mm

■ 包封 Coating

E: 環氧 (藍)
Epoxy (Blue)

H: 環氧 (黃)
Epoxy (Yellow)

■ 溫度特性 Temperature characteristics

CH: NPO
 F4: Y5V || R1: X7R | R2: X5R |

■ 芯片規格 Chip spec

D: 0603	G: 1210	J: 1825	N: 2220*2
E: 0805	H: 1808	K: 2220	
F: 1206	I: 1812	L: 2225	

■ 生產識別碼 Production identification code

內部控制碼，本規格書不作說明。
Inter control code will not be described in this an approval specifications.

獨石電容器規格承認書
APPROVAL SPECIFICATION FOR MONOLITHIC CAPACITORS

編號DOC NO.:	DEC-SA-WI006
版本REV.:	B/3
日期DATE:	2024年4月15日
頁碼PAGE:	4 / 9

5. 測量和試驗

MEASUREMENT AND TEST

序 No.	項目 Item	標準 Specifications	試驗方法 Testing Method																								
1	工作溫度範圍 Operating temp. range	-55°C~125°C																									
2	額定電壓 Rated voltage (U_R)	100V	<p>額定電壓是指在工作溫度範圍內，可連續施加在電容器上的最大直流電壓或最大交流電壓有效值或脈沖電壓的峰值。 當交流電壓附加於直流電壓時，V_{p-p}或V_{o-p}（以較大者為準）應維持在額定電壓範圍內。 The rated voltage is defined as the maximum voltage which may be applied continuously to the capacitor within the operating temperature range. When AC voltage is superimposed on DC voltage, V_{p-p} or V_{o-p}, whichever is larger, should be maintained within the rated voltage range.</p> <p>※De-rating conditions:</p> <table border="1"> <caption>De-rating conditions graph data</caption> <thead> <tr> <th>Temperature at Product (°C)</th> <th>Rated voltage (%) - 125°C</th> <th>Rated voltage (%) - 105°C</th> <th>Rated voltage (%) - 85°C</th> </tr> </thead> <tbody> <tr><td>20</td><td>100</td><td>100</td><td>100</td></tr> <tr><td>60</td><td>100</td><td>100</td><td>100</td></tr> <tr><td>85</td><td>100</td><td>100</td><td>65</td></tr> <tr><td>105</td><td>100</td><td>65</td><td>65</td></tr> <tr><td>125</td><td>65</td><td>65</td><td>65</td></tr> </tbody> </table>	Temperature at Product (°C)	Rated voltage (%) - 125°C	Rated voltage (%) - 105°C	Rated voltage (%) - 85°C	20	100	100	100	60	100	100	100	85	100	100	65	105	100	65	65	125	65	65	65
Temperature at Product (°C)	Rated voltage (%) - 125°C	Rated voltage (%) - 105°C	Rated voltage (%) - 85°C																								
20	100	100	100																								
60	100	100	100																								
85	100	100	65																								
105	100	65	65																								
125	65	65	65																								
3	外觀與尺寸 Appearance (APP) and Dimension	外觀形狀沒有明顯的缺點，尺寸在標準範圍內。 No marked defect on appearance form and dimensions are within specified range.	電容必須用目視檢查其明顯的缺點。 The capacitor should be visually inspected for evidence of defect. 尺寸用遊標卡尺測量。 Dimensions should be measured with slide calipers.																								
4	標誌 Marking	清晰易於識別。 To be easily legible.	目視檢查。 The capacitor should be visually inspected.																								
5	容量 (C_R) Capacitance (C_R)	90NF-110NF	容量與 $\tan \delta$ 在 $25 \pm 1^\circ\text{C}$ 下，使用下列條件進行測量。 The capacitance, $\tan \delta$ should be measured at $25^\circ\text{C} \pm 1^\circ\text{C}$ with the following conditions.																								
6	損耗角正切 ($\tan \delta$) Tangent of loss angle ($\tan \delta$)	0.035 max	1kHz 1V, 25°C																								
7	絕緣電阻 Insulation Resistance (IR)	1.5GΩ min	在兩導線間施加下列電壓進行測量，時間不超過1分鐘。 The insulation resistance should be measured with a DC voltage not exceeding the following voltage at normal temperature and humidity and less than 1 minute of charging. 100V																								
8	耐電壓 Testing Voltage (TV)	沒有不合格 No failure.	在電容器兩導線間施加下列測試電壓1到5s後不被破壞（充/放電流不大於2mA）。 The capacitor should not be damaged when test voltages of below are applied between the lead wires for 1 to 5 sec. (Charge/Discharge current $\leq 2\text{mA}$) 250																								
9	導線抗張強度 Terminal Tensile Strength	引線不應斷開，電容器不應破裂。 Lead wire should not be cut off capacitor should not be broken.	固定住電容器，在引線上逐步施加徑嚮拉力直至10N，並保持 10 ± 1 秒鐘。 Fix the body of the capacitor and apply a tensile weight gradually to each lead wire in the radial direction of the capacitor up to 10N and keep it for 10 ± 1 sec.																								
10	導線抗折強度 Terminal Bending Strengt	引線不應斷開，電容器不應破裂。 Lead wire should not be cut off capacitor should not be broken.	在引線出口處沿一個方嚮施加5N、 90° 的彎曲壓力，再恢復至初始狀態。之後，在2至3秒內再以相反方嚮施加一次 90° 的彎曲壓力。 Each lead wire should be subjected to 5N of weight and bent 90° at the point of egress, in one direction, then returned to its original position and bent 90° in the opposite direction at the rate of one bent in 2 to 3 sec.																								

獨石電容器規格承認書

APPROVAL SPECIFICATION FOR LEADED TYPE MLCC

續上表

Continued on the table

序 No.	項目 Item	標準 Specifications	試驗方法 Testing Method
11	可焊性 Solderability of Leads	導線必須有3/4以上的面積均勻附着焊錫 Lead wire should be soldered with uniform coating on the axial direction over 3/4 of the circumferential direction.	引線浸入焊料中 3 ± 0.5 秒鐘，浸入深度離導線根部1.5-2.0mm。 The lead wire of a capacitor should be dipped into molten solder for 3 ± 0.5 sec. The depth of immersion is up to about 1.5 to 2.0mm from the root of lead wires. 焊錫溫度: $245 \pm 5^\circ\text{C}$ Temp. of solder: $245 \pm 5^\circ\text{C}$
12	焊錫耐熱性 Soldering Effect	APP 沒有可見損傷 No marked defect	導線浸入離導線根部1.5-2.0mm處、錫溫為 $260 \pm 10^\circ\text{C}$ 中 3.5 ± 0.5 秒 The lead wires should be immersed in solder of $260 \pm 5^\circ\text{C}$ up to 1.5 to 2.0mm from the root of terminal for 3.5 ± 0.5 sec. 試驗後處理: 電容必須存放在室溫下12小時。 Post-treatment: Capacitor should be stored for 12 h at room condition.
		Δ C/C $\pm 15\%$	
		IR 符合初始標準 Meets initial specified value.	
13	振動 Vibration Resistance	APP 沒有可見損傷 No marked defect	將電容器導線焊穩和調整振動頻率範圍為10-55Hz、總振幅為1.5mm，振動從10Hz到55Hz，然後再回到10Hz，大約一分鐘。 The capacitor should be firmly soldered to the supporting lead wire and vibrated at a frequency range of 10 to 55Hz, 1.5mm in total amplitude, with about a 1 minute rate of vibration change from 10Hz to 55Hz and back to 10Hz. 總時間六個小時，每兩小時在相互垂直方向來回三次。 Apply for a total of 6 hours, 2 hours each in 3 mutually perpendicular directions.
		C_r 如第5項進行試驗，沒有不合格 Per Item 5.	
		$\tan \delta$ 如第6項進行試驗，沒有不合格 Per Item 6.	
14	溫度特性	Δ C/C: $\pm 15\%$	電容器必須按照下列每一步驟進行測量。 The capacitance measurement should be made at each step specified in below. Step Temperature ($\pm 1^\circ\text{C}$) 1 +20 2 -55 (Y5V: -30) 3 +20 4 +125 (Y5V, X5R: +85) 5 +20
15	耐濕負荷 Humidity Loading	APP 沒有可見損傷 No marked defect	施加額定電壓的電容保持在溫度為 $40 \pm 2^\circ\text{C}$ 、相對濕度為90-95%條件下 500 ± 12 小時。 Apply the rated voltage for 500 ± 12 hours at $40 \pm 2^\circ\text{C}$ in 90 to 95% relative humidity. 試驗後處理: Post-treatment: 電容必須貯存在室溫條件下24小時。 Capacitor should be stored for 24 h at room condition.
		Δ C/C $\pm 15\%$	
		$\tan \delta$ 小於初始標準的2倍 Less than 200% initial specified value.	
		IR 大於初始標準的25% More than 25% initial specified value.	
16	高溫負荷 High Temperature Load	APP 沒有可見損傷 No marked defect	在 $125 \pm 2^\circ\text{C}$ (X5R, Y5V: 85°C)、相對溫度不大於50%條件下施加下列額定電壓 $1000 + 48/-0$ 小時 (充/放電流小於2mA) Apply a DC voltage of 150% of the following voltage for $1000 + 48/-0$ hours at $125 \pm 2^\circ\text{C}$ (X5R, Y5V: 85°C) with a relative humidity of 50% max. (Charge/discharge current $\leq 2\text{mA}$) 200VDC 試驗後處理: 電容器應在室溫下儲存24小時。 Post-treatment: Capacitor shall be stored for 24 h at room condition.
		Δ C/C $\pm 20\%$	
		$\tan \delta$ 小於初始標準的1.5倍 Less than 1.50% of initial specified value.	
		IR 大於初始標準的50% More than 50% initial specified value.	
17	溫度循環 Temperature and Immersion Cycle	APP 沒有可見損傷 No marked defect	溫度循環試驗按以下條件進行試驗和測量 Temperature cycling shall be measured in the following test. Step Temperature Time 1 $-55 \pm 2^\circ\text{C}$ (Y5V, -30°C) 30min 2 $+125 \pm 2^\circ\text{C}$ (X5R, Y5V: 85°C) 30min 循環次數: 5次 Cycle numbers: 5 cycles 試驗後處理: 電容器應在室溫下儲存12小時。 Post-treatment: Capacitor shall be stored for 12 h at room condition.
		Δ C/C $\pm 15\%$	
		$\tan \delta$ 小於初始標準的1.5倍 Less than 150% of initial specified value.	
		IR 符合初始標準 Meets initial specified value.	

獨石電容器規格承認書
APPROVAL SPECIFICATION FOR MONOLITHIC CAPACITORS

編號DOC NO.: DEC-SA-WI006

版本REV.: B/3

日期DATE: 2024年4月15日

頁碼PAGE: 6 / 9

6. 包裝和儲存

PACKAGING AND STORAGE

6.1. 包裝

PACKAGING

盒裝編帶品，每盒5000pcs。

Taping of ammo packing, 5000 pcs

散包包裝，每包1000pcs (視瓷片大小不等，每箱20 000~100 000pcs)。

Bulk packing, 1000 pcs/bag (Depending on the disc size, each carton is 20 000~100 000pcs)

6.2. 貯存條件

STORAGE ENVIRONMENT

電容器絕緣包封層不是完美的密封形式，因此，請勿將電容器存放在腐蝕性氣體中，尤其是存在氯氣、硫氣、酸、堿、鹽等場所，同時應防潮。電容器應存放在溫度及相對濕度分別不超出5~40°C及15~70%範圍的場所。

The insulating coating of capacitors does not form a perfect seal; therefore, do not use or store capacitors in a corrosive atmosphere, especially where chloride gas, sulfide gas, acid, alkali, salt or the like are present. And avoid exposure to moisture. Store the capacitors where the temperature and relative humidity do not exceed 5 to 40 degrees centigrade and 15 to 70%.

請在6個月內使用電容器。超過6個月，在使用前確認其可焊性和電容量。

Use capacitors within 6 months after delivered. for more than 6 months, confirm the solderability and capacitance before use.

獨石電容器規格承認書
APPROVAL SPECIFICATION FOR MONOLITHIC CAPACITORS

編號DOC NO.: DEC-SA-WI006

版本REV.: B/3

日期DATE: 2024年4月15日

頁碼PAGE: 7 / 9

7. 測量和使用注意事項

MEASURING AND APPLICATION NOTICE

7.1. 測量注意事項

Measurement notice

請在以下條件下測量。

Please measure under the following conditions.

7.1.1. 標準大氣條件

Standard atmospheric conditions

除非另有規定，所有試驗和測量應按在IEC 60068-1的5.3中規定的試驗用標準大氣條件下表進行。

Unless otherwise specified, all tests and measurements shall be made under standard atmospheric conditions for testing as given in 5.3 of IEC 60068-1.

溫度 Temperature	相對濕度 Relative humidity	氣壓 Air pressure
15°C~35°C	25%~75%	86kPa~106kPa

在進行測量之前，電容器應在測量溫度下存放足夠時間，以使整個電容器都達到這一溫度。為此目的，規定與試驗後恢復時間同樣的時間，通常是足夠的。

Before the measurements are made, the capacitor shall be stored at the measuring temperature for a time sufficient to allow the entire capacitor to reach this temperature. The period as prescribed for recovery at the end of a test is normally sufficient for this purpose.

在標準大氣條件下進行測量，其測量結果存在爭議時應采用仲裁溫度（見7.1.3）重復測量。

Test and measurement shall be made under standard atmospheric conditions for testing, in the event of a dispute, the measurements shall be repeated using one of the referee temperatures (as given in 7.1.3).

當按某一順序進行試驗時，一個試驗的最後測量可以作為下一試驗的初始測量。

When tests are conducted in a sequence, the final measurements of one test may be taken as the initial measurements for the succeeding test.

在測量期間，不應使電容器受到氣流、陽光直射或可能引起誤差的其他影響。

During measurements the capacitor shall not be exposed to draughts, direct sunlight or other influences likely to cause error.

7.1.2. 恢復條件

Recovery conditions

除非另有規定，恢復應在試驗用標準大氣條件（見7.1.1）下進行。

Unless otherwise specified recovery shall take place under the standard atmospheric conditions for testing (7.1.1).

如果恢復必須在嚴格控制的條件下進行，應采用IEC 60068-1中5.4.1的控制條件。

If recovery under closely controlled conditions is necessary, the controlled recovery conditions of 5.4.1 of IEC 60068-1 shall be used.

除非有關規範另有規定，恢復時間應為1h~2h。

Unless otherwise specified in the relevant specification, a duration of 1 h to 2 h shall be used.

7.1.3. 仲裁條件

Referee conditions

在仲裁情況下，應選用IEC 60068-1中5.2中規定的仲裁試驗用標準大氣條件。

For referee purposes, one of the standard atmospheric conditions for referee tests taken from 5.2 of IEC 60068-1, as given in table 1 below, shall be selected:

溫度 Temperature	相對濕度 Relative humidity	氣壓 Air pressure
25°C±1°C	48%~52%	86kPa~106kPa

7.2. 工作電壓

Operating voltage

嚮電容器施加的電壓切勿超過額定電壓。

The voltage applied to the capacitor must not exceed the rated voltage.

電壓 Voltage	直流電壓 DC Voltage	直流+交流電壓 DC + AC Voltage	交流電壓 AC Voltage	脈沖電壓 Pulse Voltage
測量位置 Positional Measurement				

獨石電容器規格承認書

APPROVAL SPECIFICATION FOR MONOLITHIC CAPACITORS

編號DOC NO.:	DEC-SA-WI006
版本REV.:	B/3
日期DATE:	2024年4月15日
頁碼PAGE:	8 / 9

在交流電路或紋波電流電路中使用直流額定電壓電容器時，請務必將外加電壓的 V_{p-p} 值或包含直流偏置電壓的 V_{o-p} 值維持在額定電壓範圍內。

When DC-rated capacitors are to be used in AC or ripple current circuits, be sure to maintain the V_{p-p} value of the applied voltage or the V_{o-p} which contains DC bias within the rated voltage range.

若電路施加電壓，開始或停止時可能會因諧振或切換產生暫時的異常電壓。請務必使用額定電壓範圍包含這些異常電壓的電容器。

When the voltage is applied to the circuit, starting or stopping may generate irregular voltage for a transit period because of resonance or switching. Be sure to use a capacitor with a rated voltage range that includes these irregular voltages.

7.3. 過電壓影響

Overvoltage effects

施加到電容器的過電壓可能會導致電容器內部介質層擊穿而引起電路短路。

The overvoltage applied to the capacitor may cause the dielectric layer of the capacitor to break down and cause a short circuit.

擊穿前的可持續時間取決於施加電壓和周圍溫度。

The duration before the breakdown depends on the applied voltage and the ambient temperature.

7.4. 焊錫

Soldering

當在PCB/PWB焊錫這個產品時，不要超過電容器的焊錫耐熱性標準。過度的熱量會使電容器內部焊錫熔化，可能導致熱衝擊而使陶瓷介質出現暗裂。

When soldering this product to a PCB/PWB, do not exceed the solder heat resistance specifications of the capacitor. Subjecting this product to excessive heating could melt the internal junction solder and may result in thermal shocks that can crack the ceramic element.

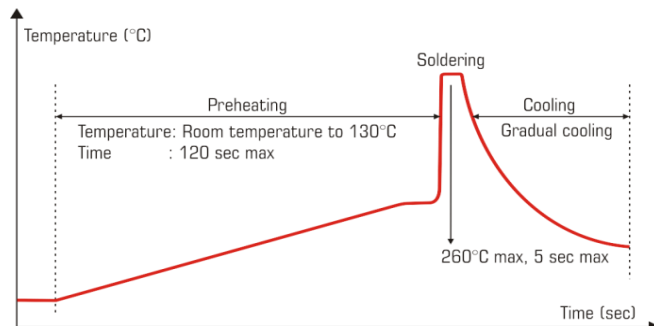

Fig.: Wave-soldering temperature-time profile to recommend

當使用烙鐵進行手工焊錫時，應該遵照下列條件：

When soldering capacitor with a soldering iron, it should be performed in the following conditions.

焊錫溫度：320°C最大

Temperature of iron-tip: 320 degrees C. Max.

烙鐵頭：不超過40W

Soldering iron wattage: 40W max.

焊錫時間：不超過3.0秒

Soldering time: 3.0 sec. Max.

