



# 栅极驱动光耦

## Gate Drive Optocoupler

# AT314

## Product Data Sheet

**AOTE DCC**  
**RELEASE**

**台湾奥特半导体科技有限公司**

TAIWAN AOTE SEMICONDUCTOR TECHNOLOGY CO.,LTD

[www.aotesemi.com](http://www.aotesemi.com)

## 概述 Description

AT314 是一种输出电流为 0.6A 的栅极驱动光电耦合器，具有一个镓砷磷化合物 (GaAsP) 的发光二极管，通过红外光耦合到光敏集成电路。这种光电耦合器可驱动大多数的小功率 IGBTs 和 MOSFETs。在电机控制逆变器以及高性能电力系统应用中，其非常适用于快速切换驱动功率 IGBTs 和 MOSFETs。

The AT314 is a gate driven optocoupler with an output current of 0.6 A, with an GaAsP LED, which is coupled to a photosensitive integrated circuit through infrared light. This optocoupler can drive most low-power IGBTs and MOSFETs. In the motor control inverter and high-performance power system applications, it is very suitable for fast switching drive power IGBTs and MOSFETs.

## 特性 Features

- 25kV/us 最小共模抑制  
25 kV/μs minimum Common Mode Rejection
- 宽工作电压范围：10V 至 30V  
Wide operating VCC Range: 10V ~ 30V;
- 工作温度范围：-40°C to +105°C;  
Operating temperature range: -40°C ~ +105°C;
- 延迟时间最大为 700ns  
700ns maximum propagation delay
- 开关速度快  
Switch fast
- 0.4A 最小峰值输出电流  
0.4A Minimum peak output current
- 0.6A 最大峰值输出电流  
0.6A Maximum peak output current
- 符合加强绝缘标准  
Meet reinforced insulation standards

## 应用 Applications

- 开关电源  
Switching power supplies
- IGBT/MOSFET 栅极驱动器  
IGBT/MOSFET gate drive
- 交流和无刷直流电机驱动器  
AC and Brushless DC motor drives
- 可再生能源逆变器  
Renewable energy inverters
- 工业逆变器  
Industrial inverters

## 真值表 Truth table

| LED | V <sub>CC</sub> -V <sub>EE</sub><br>"Positive Going"<br>(Turn-on) |                | V <sub>CC</sub> -V <sub>EE</sub><br>"Negative Going"<br>(Turn-off) |                |
|-----|---|----------------|--|----------------|
|     | V <sub>CC</sub> -V <sub>EE</sub>                                  | V <sub>O</sub> | V <sub>CC</sub> -V <sub>EE</sub>                                   | V <sub>O</sub> |
| OFF | 0V to 30V   | Low            | 30V to 0V  | Low            |
| ON  | 0V to 6.9V  | Low            | 30V to 7.5V  | High           |
| ON  | 6.9V to 8.7V  | Transition     | 7.5V to 5.9V   | Transition     |
| ON  | 8.7V to 30V   | High           | 5.9V to 0V   | Low            |

## 封装和原理图 Package and Schematic Diagram

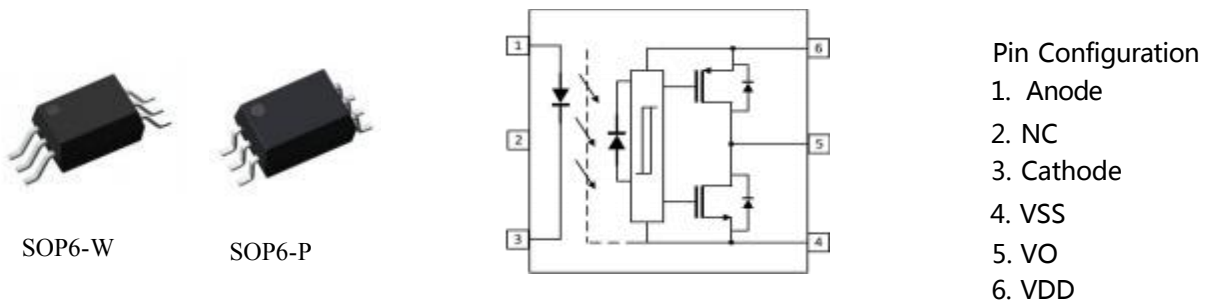

注：在引脚 4 和 6 之间必须连接一个 1uF 的旁路电容器。

Note: A 1uF bypass capacitor must be connected between pins 4 and 6.

## 产品型号命名规则 Order Code

# AT 314 - UN Y - W (V) (ZZ)

①      ②      ③      ④      ⑤      ⑥      ⑦

- ① 公司代码 Company Code ( AT: 奥特 AOTE )
- ② 产品系列 Product Series ( 314 )
- ③ 框架类型 Lead Frame ( Cu: 铜框架 Copper )
- ④ 树脂类型 Epoxy Type ( H: 无卤 Halogen-free )
- ⑤ 封装形式 Package ( P: PSOP; W: WSOP )
- ⑥ 器件工作温度范围 Device Operating Temperature Range ( 特殊范围需填或者空白 Special Range need to be filled in or left blank )
- ⑦ 内部补充代码 Internal Supplementary Code ( 数字或者空白 Number or None )

## 印字信息 Marking Information

- . 印字中 “” 为奥特品牌 LOGO “” denotes LOGO
- . 印字中 “” 代表年份 : A(2018), B(2019), C(2020)..... “” denotes YEAR : A(2018) B(2019), C(2020).....
- . 印字中 “WW” 代表周号  
“WW” denotes Week' s number
- . 印字中的 “E” 代表经济型产品  
“E” denotes the economical product. 印字中的 “H” 代表无卤  
“H” denotes Halogen-free

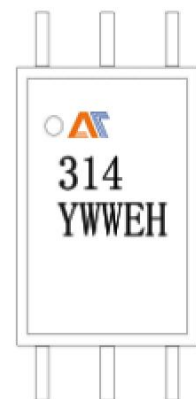

**绝缘和安规信息 Insulation and Safety related specifications**

| 项目<br>Item                            | 符号<br>Symbol | 数值<br>Value | 单位<br>Unit | 备注<br>Note  |
|---------------------------------------|--------------|-------------|------------|---|
| 爬电距离<br>Creepage Distance             | L            | ≥8.0        | mm         | 从输入端到输出端，沿本体最短距离路径<br>Measured from input terminals to output terminals, shortest distance path along body. |
| 电气间隙<br>Clearance Distance            | L            | ≥8.0        | mm         | 从输入端到输出端，通过空气的最短距离<br>Measured from input terminals to output terminals, shortest distance through air.     |
| 绝缘距离<br>Insulation Thickness          | DTI          | ≥0.4        | mm         | 发射器和探测器之间的绝缘厚度<br>Insulation thickness between emitter and detector.  |
| 峰值隔离电压<br>Peak Isolation Voltage      | $V_{IORM}$   | 1500        | $V_{peak}$ | DIN/EN/IEC EN60747-5-5.   |
| 瞬态隔离电压<br>Transient Isolation Voltage | $V_{IOTM}$   | 7000        | $V_{peak}$ | DIN/EN/IEC EN60747-5-5.   |
| 隔离电压<br>Isolation Voltage             | $V_{ISO}$    | 5000        | $V_{rms}$  | $T_A = 25^{\circ}C, RH < 50\%$ for 1 min.   |

**极限参数 Absolute Maximum Ratings ( $T_A = 25^{\circ}C$ )**

| 参数<br>Parameter                |  | 符号<br>Symbol    | 最小值<br>Min. | 最大值<br>Max. | 单位<br>Unit  |
|--------------------------------|--|-----------------|-------------|-------------|-------------|
| 输入<br>Input                    | 平均输入电流<br>Average Current Input  | $I_{F(AVG)}$    | -           | 25          | mA          |
|                                | 峰值瞬态输入电流 ( <1 us pulse, 300pps )<br>Peak Transient Input Current ( <1 us Pulse, 300pps ) | $I_{F(TRAN)}$   | -           | 1.0         | A           |
|                                | 反向电压<br>Reverse Voltage  | $V_R$           | -           | 5           | V           |
|                                | 输入功耗<br>Power Dissipation  | $P_I$           | -           | 45          | mW          |
| 输出<br>Output                   | 高峰值输出电流<br>High Peak Output Current  | $I_{OH(PEAK)}$  | -           | 0.6         | A           |
|                                | 低峰值输出电流<br>Low Peak Output Current   | $I_{OL(PEAK)}$  | -           | 0.6         | A           |
|                                | 电源电压<br>Supply Voltage   | $V_{CC}-V_{EE}$ | -0.5        | 35          | V           |
|                                | 峰值输出电压<br>Peak Output Voltage  | $V_{O(PECK)}$   | 0.5         | $V_{CC}$    | V           |
|                                | 输出功耗<br>Power Dissipation  | $P_O$           | -           | 250         | mW          |
| 总功耗<br>Total Power Dissipation |  | $P_{tot}$       | -           | 295         | mW          |
| 隔离电压<br>Isolation Voltage      |  | $V_{ISO}$       | 5000        | -           | $V_{rms}$   |
| 工作温度<br>Operating Temperature  |  | $T_{opr}$       | -40         | +105        | $^{\circ}C$ |
| 储存温度<br>Storage Temperature    |  | $T_{STG}$       | -55         | +125        | $^{\circ}C$ |
| 焊接温度<br>Soldering Temperature  |  | $T_{sol}$       | -           | 260         | $^{\circ}C$ |

**推荐操作条件 Recommended Operating Conditions**

| 参数<br>Parameter               | 符号<br>Symbol    | 最小值<br>Min | 最大值<br>Max | 单位<br>Unit |
|-------------------------------|-----------------|------------|------------|------------|
| 电源电压<br>Power Supply Voltage  | $V_{CC}-V_{EE}$ | 10         | 30         | V          |
| 开启电流<br>Input Current (ON)    | $I_{F(ON)}$     | 8          | 12         | mA         |
| 关断电压<br>Input Voltage (OFF)   | $V_{F(OFF)}$    | -3.6       | 0.8        | V          |
| 工作温度<br>Operating Temperature | $T_A$           | -40        | +105       | °C         |

**产品特性参数 Electro-optical Characteristics ( $T_A = 25^\circ\text{C}$ )**

除非另有规定，适用于所有的推荐条件，典型值在  $T_A = 25^\circ\text{C}$  下测量

Unless otherwise specified, as appropriate for all recommended conditions, typical values are measured at  $T_A = 25^\circ\text{C}$

| 参数<br>Parameter                            | 符号<br>Symbol  | 条件<br>Condition                      | 最小<br>Min.                          | 典型<br>Typ.                 | 最大<br>Max.     | 单位<br>Unit |       |
|--|---|--------------------------------------|-------------------------------------|----------------------------|----------------|------------|-------|
| 发射端<br>Input                               | 正向电压<br>Forward Voltage   | $V_F$                                | $I_f = 10\text{mA}$                 | 1.2                        | 1.4            | 1.8        | V     |
|  | 反向电压<br>Reverse Voltage   | $B_{VR}$                             | $I_r = 10\mu\text{A}$               | 5                          | -              | -          | V     |
|  | 阈值电流从低到高<br>Threshold Input Current Low to High                 | $I_{FLH}$                            | $I_o = 0\text{mA}, V_o > 5\text{V}$ | -                          | 1.4            | 7          | mA    |
|  | 阈值电压从高到低<br>Threshold Input Voltage High to Low                 | $V_{FHL}$                            | $I_o = 0\text{mA}, V_o < 5\text{V}$ | 0.8                        | -              | -          | V     |
|  | 输入正向电压的温度系数<br>Temperature Coefficient Of Input Forward Voltage | $\Delta V_F / \Delta T_A$            | $I_f = 10\text{mA}$                 | -                          | -1.6           | -          | mV/°C |
|  | 输入电容<br>Input Capacitance                                       | $C_{IN}$                             | $V = 0, F = 1\text{kHz}$            | -                          | 60             | -          | pF    |
|  | 接收端<br>Output   | 高电平输出电流<br>High Level Output Current | $I_{OH}$                            | $V_o = V_{CC} - 4\text{V}$ | 0.2            | -          | -     |
| $V_o = V_{CC} - 10\text{V}$                |   |                                      |                                     | 0.4                        | 0.5            | -          |       |
| 低电平输出电流<br>Low Level Output Current        |   | $I_{OL}$                             | $V_o = V_{EE} + 2.5\text{V}$        | 0.2                        | 0.4            | -          |       |
|  |   |                                      | $V_o = V_{EE} + 10\text{V}$         | 0.4                        | 0.5            | -          |       |
| 高电平输出电压<br>High Level Output Voltage       |   | $V_{OH}$                             | $I_o = -100\text{mA}$               | $V_{CC} - 0.3$             | $V_{CC} - 0.1$ | -          | V     |
| 低电平输出电压<br>Low Level Output Voltage        |   | $V_{OL}$                             | $I_o = 100\text{mA}$                | -                          | 0.2            | 1          | V     |
| 高电平电源电流<br>High Level Power Supply Current |   | $I_{CCH}$                            | $I_f = 10\text{mA}$                 | -                          | 1.5            | 3          | mA    |
| 低电平电源电流<br>Low Level Power Supply Current  | $I_{CCL}$   | $I_f = 0\text{mA}$                   | -                                   | 1.5                        | 3              |            |       |

| 参数<br>Parameter                     | 符号<br>Symbol  | 条件<br>Condition | 最小<br>Min.   | 典型<br>Typ.                              | 最大<br>Max. | 单位<br>Unit |          |             |
|-------------------------------------|---|-----------------|--|---|------------|------------|----------|-------------|
| 传输特性<br>Transfer<br>Characteristics | 低电压锁定阈值<br>UVLO Threshold                                     | $V_{UVLO+}$     | $I_f = 10mA, V_o > 5V$   | 6.9                                     | 7.8        | 8.7        | V        |             |
|                                     |   | $V_{UVLO-}$     | $I_f = 10mA, V_o < 5V$   | 5.9                                     | 6.7        | 7.5        | V        |             |
|                                     | 低电压锁定阈值迟滞<br>UVLO Hysteresis                                  | $U_{VLOHYS}$    | -  | -                                       | 1.1        | -          | V        |             |
|                                     | 低电平传输延迟<br>Propagation Delay Time to Low Output Level         | $T_{PHL}$       | $V_{CC} = 30V$<br>$I_f = 8mA$<br>$R_g = 47\Omega$<br>$C_g = 3nF$<br>$f = 10 kHz$<br>Duty Cycle = 50% | 0.1                                     | 0.16       | 0.7        | us       |             |
|                                     | 高电平传输延迟<br>Propagation Delay Time to High Output Level        | $T_{PLH}$       |  | 0.1                                     | 0.13       | 0.7        | us       |             |
|                                     | 传输延迟差<br>Propagation Delay Difference Between Any Two Parts   | PDD             |  | -0.5                                    | -          | 0.5        | us       |             |
|                                     | 上升时间(10%~90%)<br>Rise Time (10% To 90%)                       | $T_R$           |  | -                                       | 15         | -          | ns       |             |
|                                     | 下降时间(90%~10%)<br>Fall Time (90%~10%)                          | $T_F$           |  | -                                       | 10         | -          | ns       |             |
|                                     | 输出高电平共模抑制<br>Output High Level Common Mode Transient Immunity | $ CM_H $        |  | $T_A = 25^\circ C,$<br>$V_{CM} = 1500V$ | 25         | -          | -        | kV/ $\mu s$ |
|                                     | 输出低电平共模抑制<br>Output Low Level Common Mode Transient Immunity  | $ CM_L $        |  |   | 25         | -          | -        | kV/ $\mu s$ |
|                                     | 隔离电阻<br>Isolation Resistance                                  | $R_{ISO}$       | $V_{I-O} \leq 500V$  | $10^{12}$                               | -          | -          | $\Omega$ |             |
|                                     | 隔离电容<br>Isolation Capacitance                                 | $C_{ISO}$       | $V_{I-O} = 0V$<br>$f = 1.0MHz$   | -                                       | 0.8        | -          | pF       |             |

**典型光电特性曲线 Typical Electro-Optical Characteristics Curves**

Fig.1 High Level Output Voltage vs. Ambient Temperature

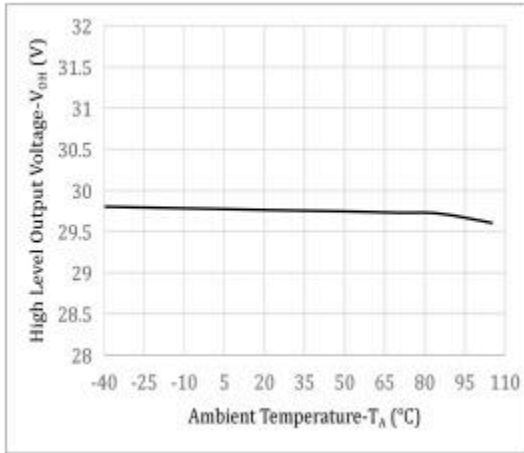

Fig.2 High Level Output Current vs. Ambient Temperature

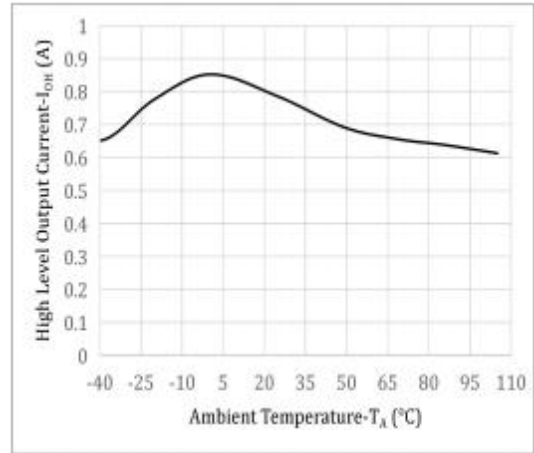

Fig.3 High Level Output Voltage vs. High Level Output Current

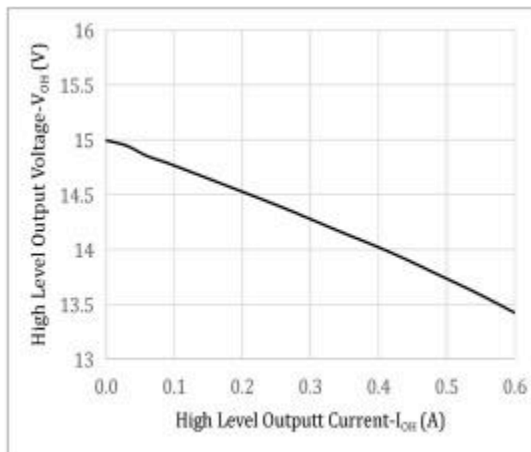

Fig.4 Low Level Output Voltage vs. Ambient Temperature

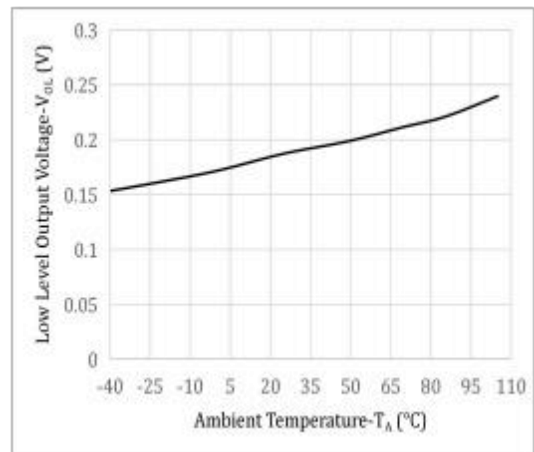

Fig.5 Low Level Output Current vs. Ambient Temperature

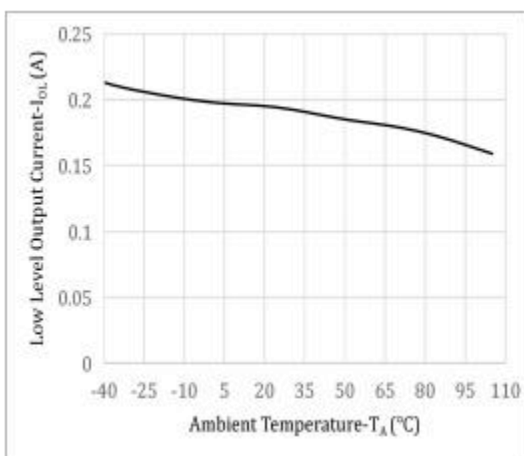

Fig.6 Low Level Output Voltage vs. Low Level Output Current

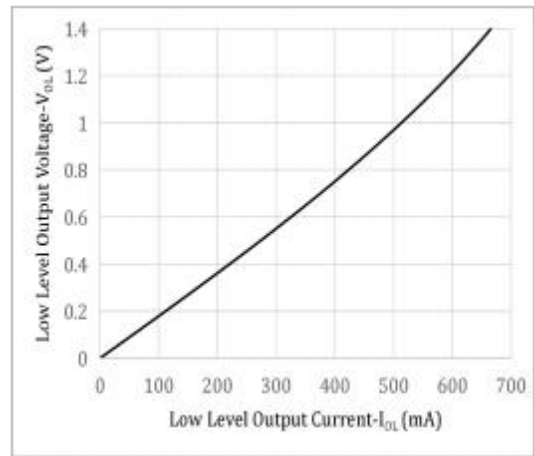

Fig.7 Supply Current vs. Ambient Temperature

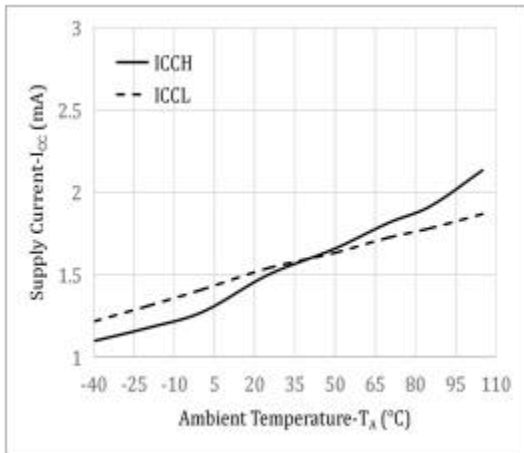

Fig.8 Supply Current vs. Supply Voltage

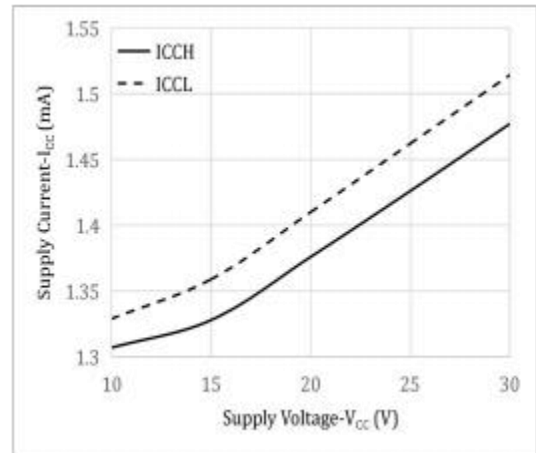

Fig.9 Threshold Input Current Low to High vs. Ambient Temperature

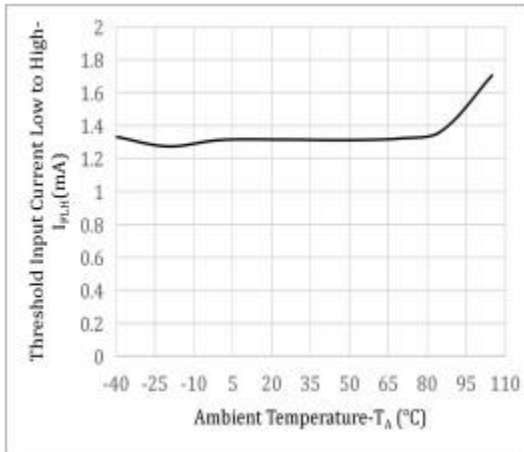

Fig.10 Propagation Delay vs. Supply Voltage

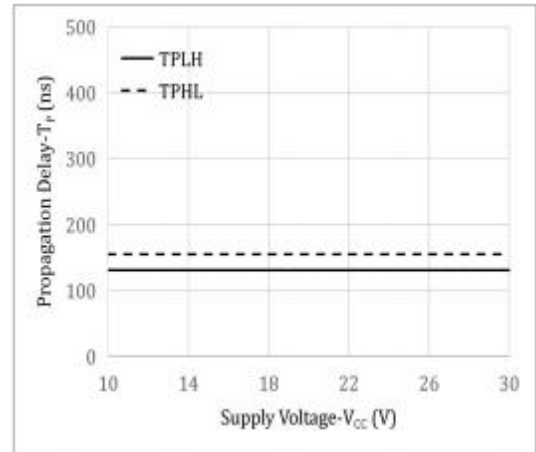

Fig.11 Propagation Delay vs. Input Forward Current

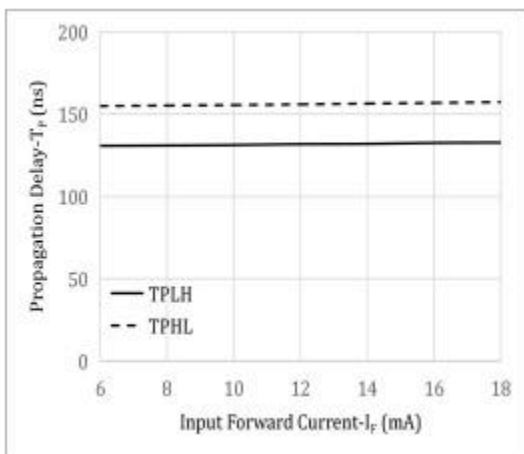

Fig.12 Propagation Delay vs. Ambient Temperature

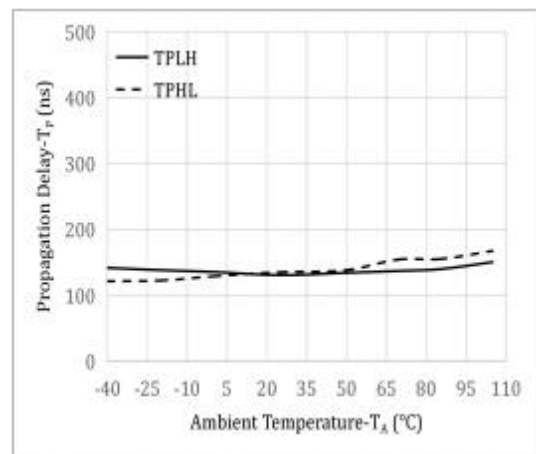



Fig.13 Propagation Delay vs. Load Resistance

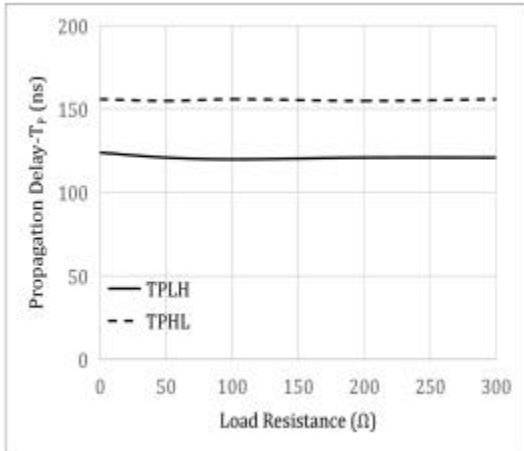

Fig.14 Propagation Delay vs. Load Capacitance

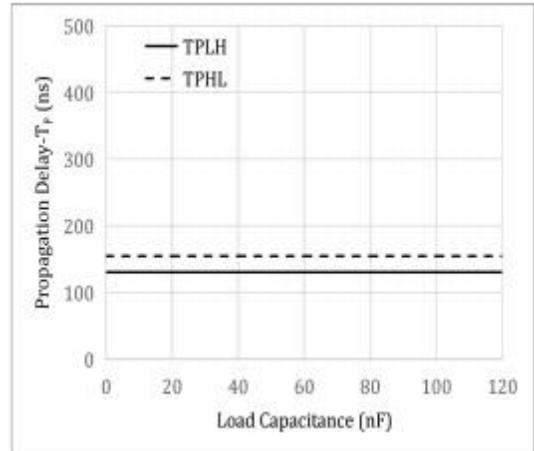

Fig.15 Output Voltage vs. Forward Current

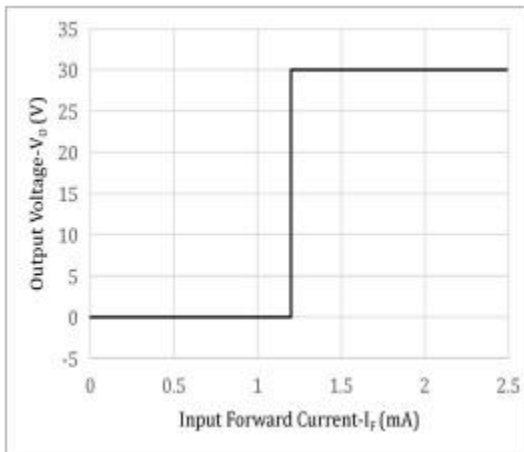

Fig.16 Input Forward Current vs. Forward Voltage

**测试电路 Test Circuits**

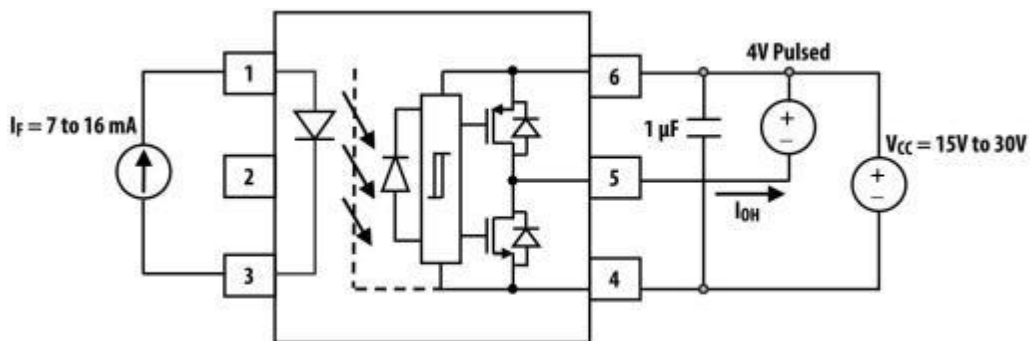

Figure.17  $I_{OH}$  Pulsed Test Circuit

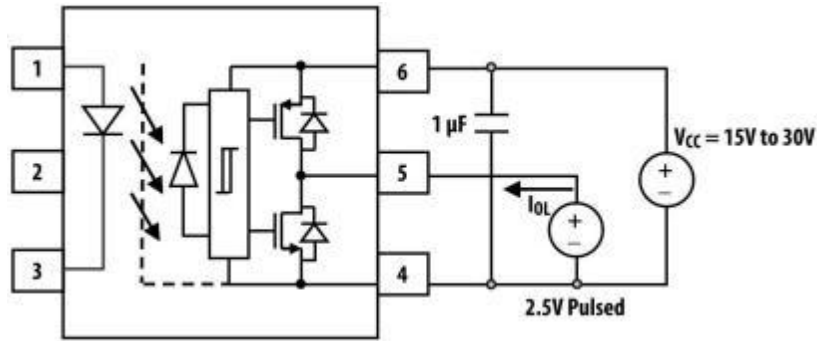

Figure.18  $I_{OL}$  Pulsed Test Circuit

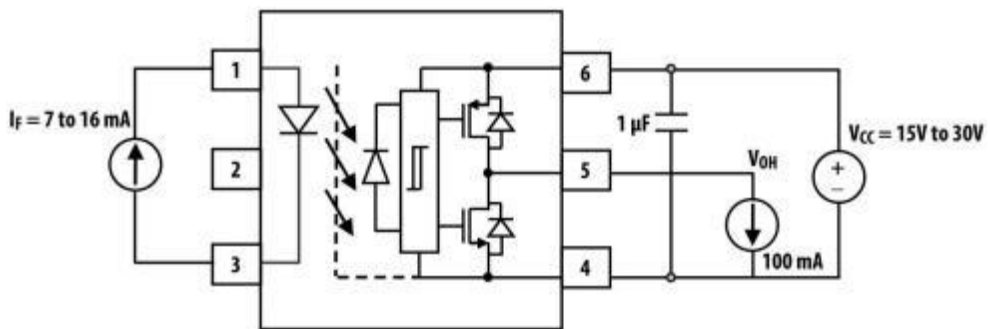

Figure.19  $V_{OH}$  Pulsed Test Circuit

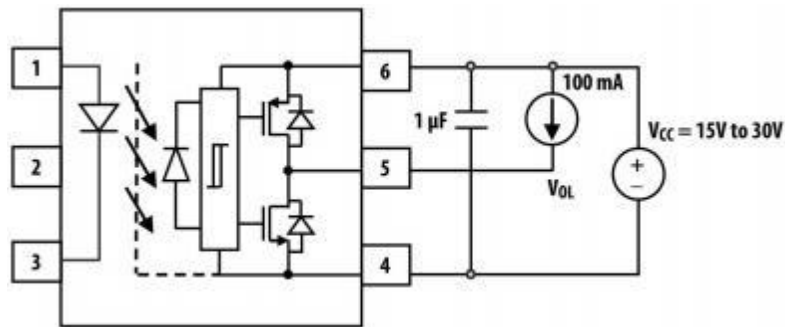

Figure.20  $V_{OL}$  Pulsed Test Circuit

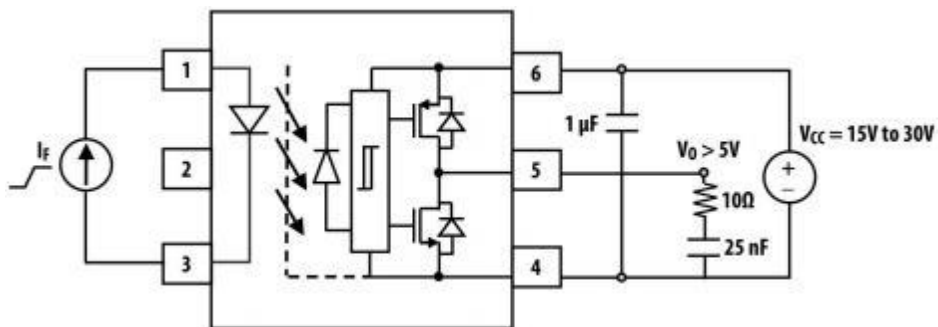

Figure.21  $I_{FLH}$  Test Circuit

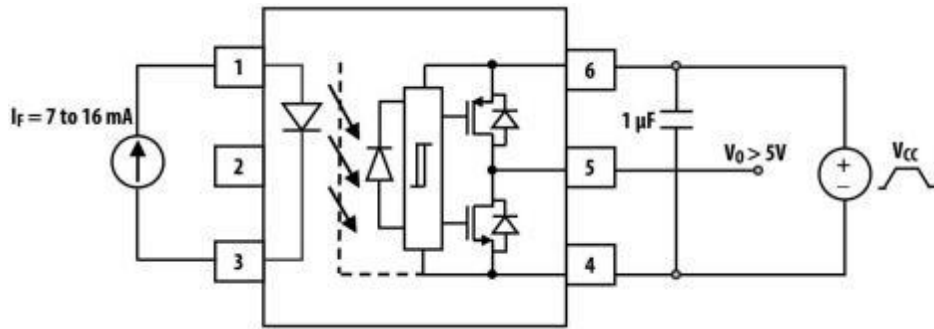

Figure.22 UVLO Test Circuit

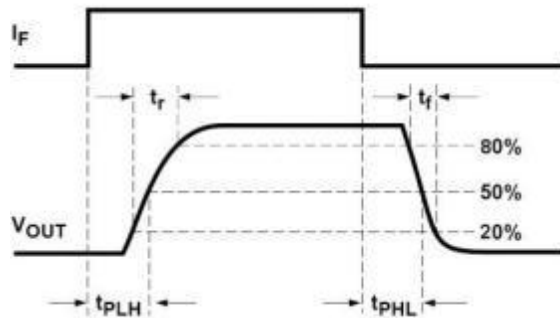
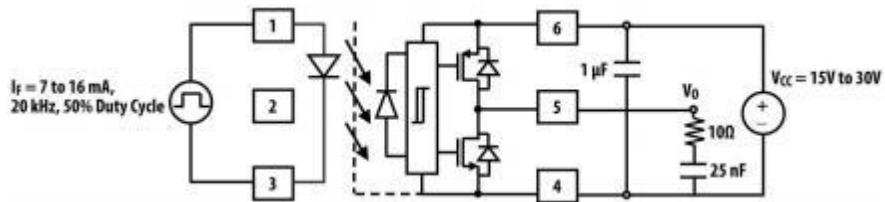

Figure.23  $T_{PHL}$ ,  $T_{PLH}$ ,  $T_R$ ,  $T_F$  Test Circuit

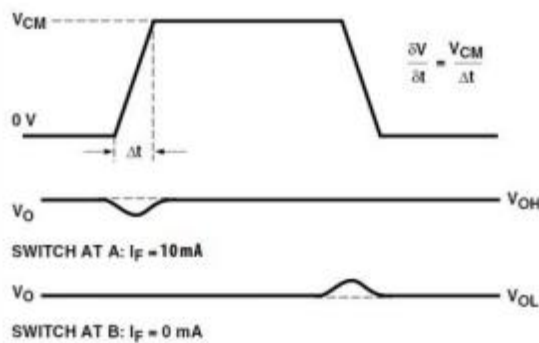
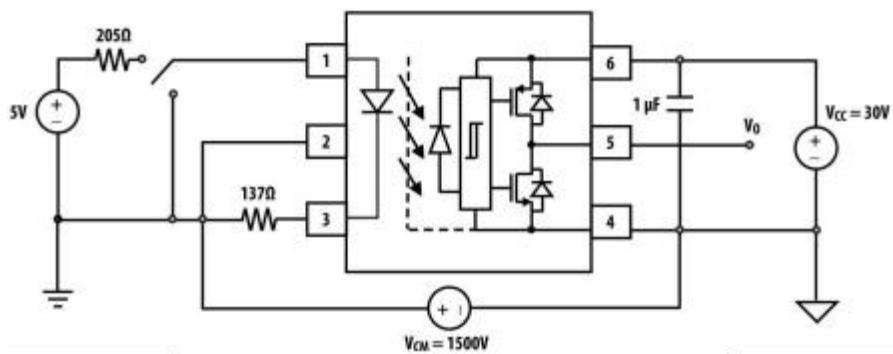
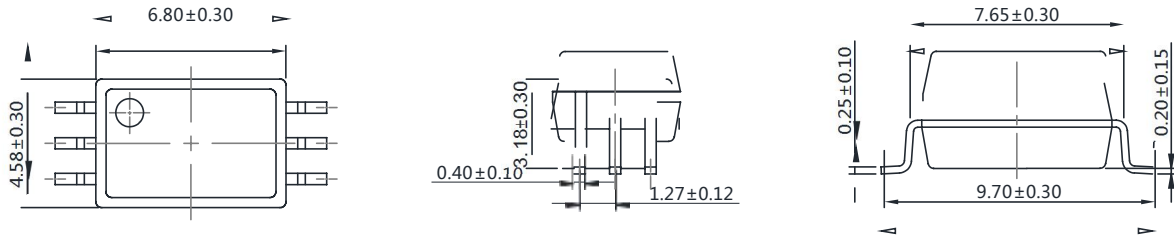

Figure.24 CMR Test Circuit

## 外形尺寸 Outline Dimensions

### SOP6-P



### SOP6-W

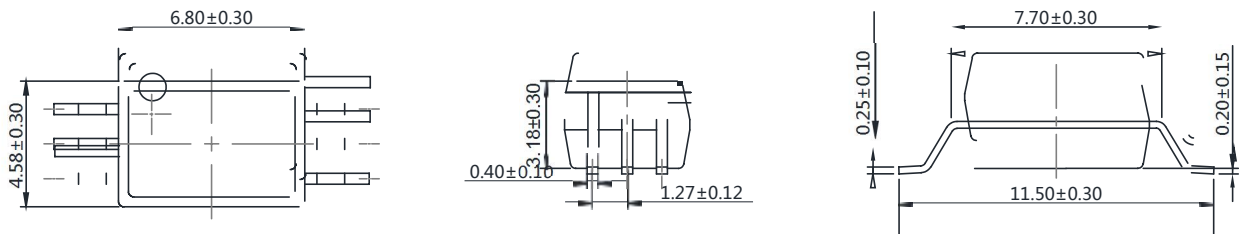

单位 Unit: mm

## 建议焊盘布局 Recommended Pad Layout

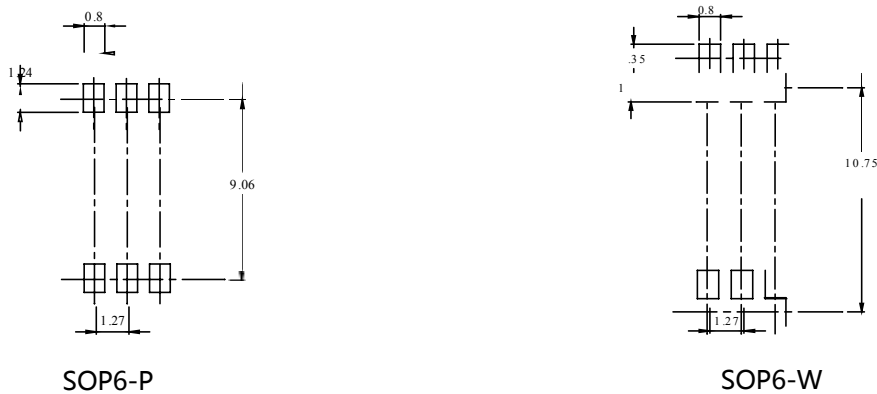

SOP6-P

SOP6-W

单位 Unit: mm

注：上图为产品正视图。  
Note: The picture above is the front view of the product.

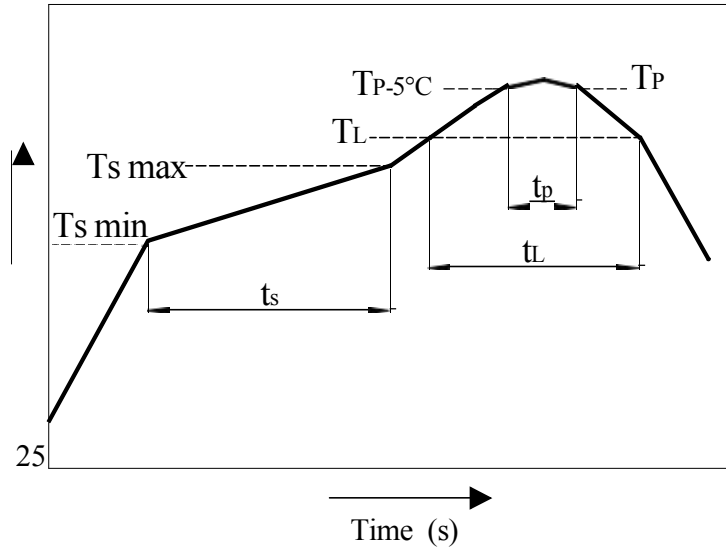
**回流焊温度曲线图 Solder Reflow Profile**

| 项目<br>Item  | 符号<br>Symbol | 最小值<br>Min. | 最大值<br>Max | 单位<br>Unit |
|---|--------------|-------------|------------|------------|
| 预热温度<br>Preheat Temperature   | $T_s$        | 150         | 200        | °C         |
| 预热时间<br>Preheat Time  | $t_s$        | 60          | 120        | s          |
| 升温速率<br>Ramp-Up Rate ( $T_L$ to $T_P$ )   | -            | -           | 3          | °C/s       |
| 液相线温度<br>Liquidus Temperature   | $T_L$        | 217         |            | °C         |
| 时间高于 $T_L$<br>Time Above $T_L$  | $t_L$        | 60          | 150        | s          |
| 峰值温度<br>Peak Temperature  | $T_P$        | -           | 260        | °C         |
| $T_C$ 在 $(T_P-5)$ 和 $T_P$ 之间的时间<br>Time During Which $T_C$ Is Between $(T_P-5)$ and $T_P$ | $t_p$        | -           | 30         | s          |
| 降温速率<br>Ramp-down Rate ( $T_P$ to $T_L$ )   | -            | -           | 6          | °C/s       |

注：建议在所示的温度和时间条件下进行回流焊，最多不能超过三次。

Note: Reflow soldering is recommended at the temperatures and times shown, no more than three times.

## 波峰焊温度曲线图 Wave Soldering Profile

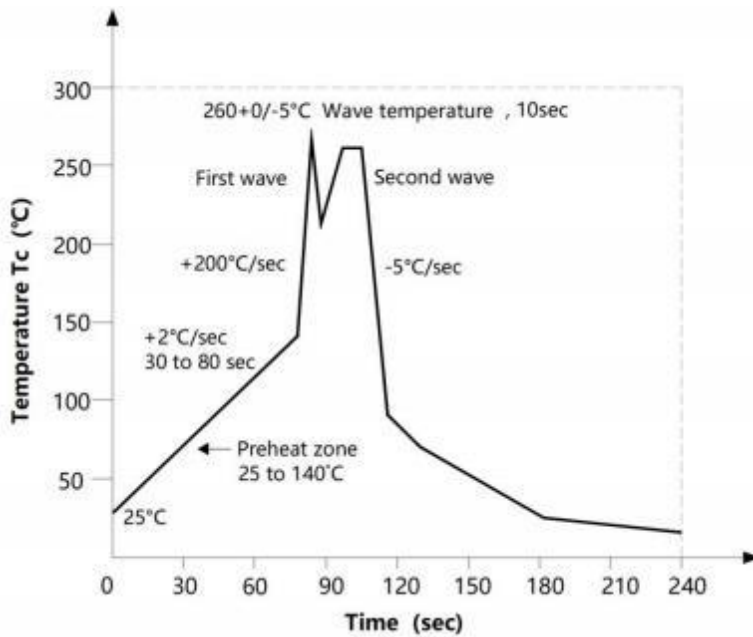

## 手工烙铁焊接 Soldering with hand soldering iron

- A. 手工烙铁焊仅用于产品返修或样品测试；  
Hand soldering iron is only used for product rework or sample testing;
- B. 手工烙铁焊要求：温度  $360^{\circ}\text{C} \pm 5^{\circ}\text{C}$ ，时间  $\leq 3\text{s}$ 。  
Manual soldering method Temperature:  $360^{\circ}\text{C} \pm 5^{\circ}\text{C}$ , within 3s.

## 包装 Packing

### ■ 汇总表 Summary table

| 封装形式         | 包装方式                          | 盘数量               | 盒数量              | 箱数量                 | 静电袋规格                        | 盒规格               | 箱(双瓦楞)规格             | 备注   |
|--------------|-------------------------------|-------------------|------------------|---------------------|------------------------------|-------------------|----------------------|--|
| SOP6         | 卷盘<br>( $\phi 330$ mm 蓝盘)     | 1000<br>只/盘       | 2 盘/盒            | 10 盒/箱              | 380*380mm                    | 340*60*340<br>mm  | 620*360*365mm        | 首尾端空至少 200mm   |
| Package Type | Packing Form                  | Quantity per Reel | Quantity per Box | Quantity per Carton | Antistatic Bag Specification | Box Specification | Carton Specification | Note   |
| SOP6         | Reel<br>( $\phi 330$ mm Blue) | 1k<br>pcs/reel    | 2 Reel/box       | 10 box/ctn          | 380*380mm                    | 340*60*340<br>mm  | 620*360*365mm        | Leave at least 200mm<br>of blank space at<br>both ends |

### ■ 编带包装 Tape & Reel

- 1) 每卷数量：1000 只。  
Qty/reel：1000 pcs.
- 2) 每箱数量：20000 只。  
Qty/ctn：20000 pcs.
- 3) 内包装：每盒 2 盘。  
Inner packing：2 reels/box.
- 4) 示意图 Schematic：

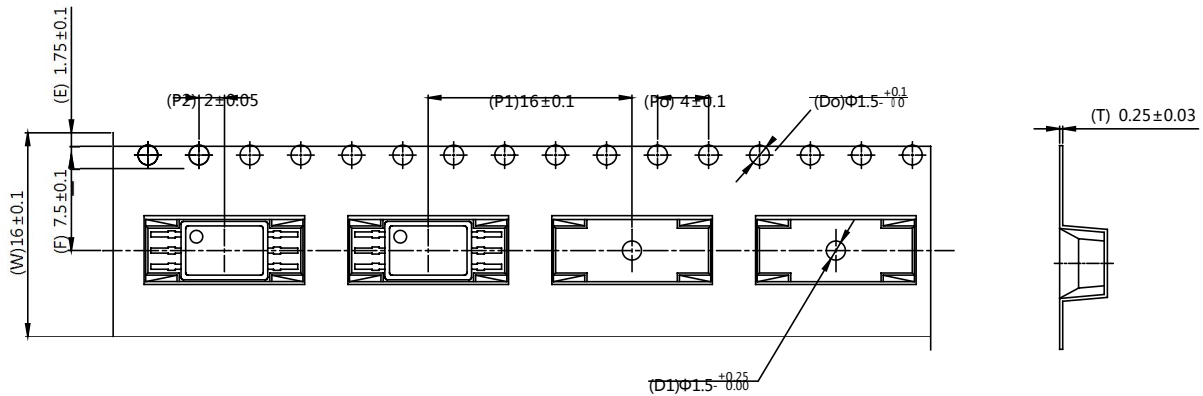

单位 Unit：mm

## 注意 Attention

- 奥特持续不断改进质量、可靠性、功能或设计，保留此文件更改的权利恕不另行通知。  
AOTE continuously improve quality, reliability, function or design. We reserve the right to change this document without notice.
- 请遵守产品规格书使用，奥特不对使用时不符合产品规格书条件而导致的质量问题负责。  
Please use in accordance with the product specification. AOTE is not responsible for the quality problems caused by non-compliance with the product specifications.
- 对于需要高可靠性或安全性的设备/装置需求，请联系我们的销售人员。  
For equipment/devices where high reliability or safety is required, please contact our sales representatives.
- 当需要用于任何“特定”应用时，请咨询我们的销售人员。  
When requiring a device for any “specific” application, please contact our sales in advice.
- 如对文件中表述的内容有疑问，欢迎联系我们。  
If you have any questions about the contents of the document, please contact us.