

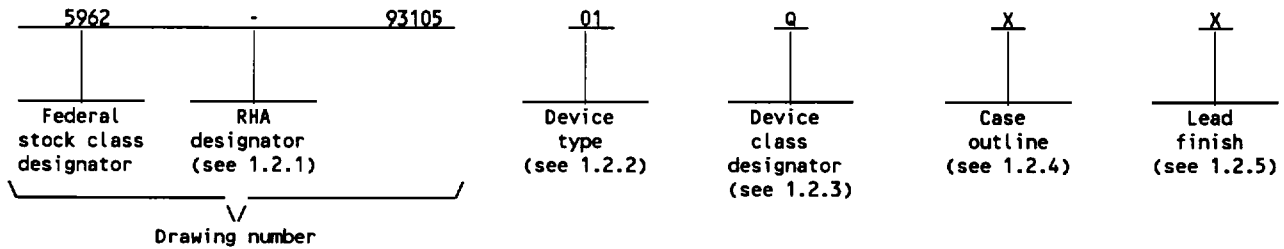

**1. SCOPE**

1.1 Scope. This drawing documents three product assurance class levels consisting of space application (device class Q), high reliability (device classes M and Q), and non traditional performance environment (device class N). A choice of case outlines and lead finishes are available and are reflected in the Part or Identifying Number (PIN). When available, a choice of Radiation Hardness Assurance (RHA) levels are reflected in the PIN. For device class N, the user is cautioned to assure that the device is appropriate for the application environment.

1.2 PIN. The PIN is as shown in the following example:



1.2.1 RHA designator. Device classes N, Q and V RHA marked devices meet the MIL-PRF-38535 specified RHA levels and are marked with the appropriate RHA designator. Device class M RHA marked devices meet the MIL-PRF-38535, appendix A specified RHA levels and are marked with the appropriate RHA designator. A dash (-) indicates a non-RHA device.

1.2.2 Device type(s). The device type(s) identify the circuit function as follows:

<u>Device type</u>	<u>Generic number</u>	<u>Circuit function</u>
01	80486DX-25	32 Bit High Integration Microprocessor
02	80486DX-33	32 Bit High Integration Microprocessor
03 1/	80486DX2-50	32 Bit High Integration Microprocessor
04 1/	80486DX2-66	32 Bit High Integration Microprocessor
05 1/	80486DX-25	32 Bit High Integration Microprocessor
06 1/	80486DX-33	32 Bit High Integration Microprocessor
07 1/	80486DX2-50	32 Bit High Integration Microprocessor
08 1/	80486DX2-66	32 Bit High Integration Microprocessor
09 1/	80486DX2-50	32 Bit High Integration Microprocessor
10 1/	80486DX2-66	32 Bit High Integration Microprocessor

1.2.3 Device class designator. The device class designator is a single letter identifying the product assurance level as follows:

<u>Device class</u>	<u>Device requirements documentation</u>
M	Vendor self-certification to the requirements for MIL-STD-883 compliant, non-JAN class level B microcircuits in accordance with MIL-PRF-38535, appendix A
N	Certification and qualification to MIL-PRF-38535 with nontraditional performance environment 2/
Q or V	Certification and qualification to MIL-PRF-38535

1.2.4 Case outline(s). The case outline(s) are as designated in MIL-STD-1835 and as follows:

<u>Outline letter</u>	<u>Descriptive designator</u>	<u>Terminals</u>	<u>Package style</u>
X	CMGA9-P168	168	Ceramic, pin grid array
Y	See Figure 1	196	Leaded chip carrier with

1.2.5 Lead finish. The lead finish is as specified in MIL-PRF-38535 for device classes Q and V or MIL-PRF-38535, appendix A for device class M.

1/ Device types 03 and 04 provide testability features compatible with the IEEE Standard Test Access Port and Boundry Scan Architecture (IEEE Standard 1149.1). Device type 05, 06, 07, 08, 09 and 10 are JTAG compatible and have the system management enhancement (SL).

2/ Any device outside the traditional performance environment; e.g., an operating temperature range for device types 01-08 -55°C to +125°C and device types 09 and 10 -40°C to +110°C and which requires hermetic packaging.

<b>STANDARD MICROCIRCUIT DRAWING DEFENSE SUPPLY CENTER COLUMBUS COLUMBUS, OHIO 43216-5000</b>	<b>SIZE A</b>		<b>5962-93105</b>
		<b>REVISION LEVEL C</b>	<b>SHEET 2</b>

1.3 Absolute maximum ratings. 2/

Storage temperature range . . . . .	-65°C to +150°C
Supply voltage with respect to ground range . . . . .	-0.5V dc to +6.5V dc
Voltage on any pin with respect to ground range . . . . .	-0.5V dc to +5.5V dc
Maximum power dissipation (P <sub>D</sub> )	
Device 01 and 05 . . . . .	3.675 W
Device 02 and 06 . . . . .	4.725 W
Device 03, 07, 09 . . . . .	4.988 W
Device 04, 08, 10 . . . . .	6.3 W
Lead temperature (soldering, 10 seconds) . . . . .	300°C
Thermal resistance, junction-to-case (θ <sub>JC</sub> ):	
Case X . . . . .	1.5°C/W
Case Y . . . . .	2.5°C/W
Maximum junction temperature (T <sub>J</sub> )	
Devices 01,02,05,06: Case X (T <sub>J</sub> ) = 132.1°C; Case Y (T <sub>J</sub> ) = 136.8°C	
Devices 03,04,07,08: Case X (T <sub>J</sub> ) = 134.5°C; Case Y (T <sub>J</sub> ) = 140.8°C	
Devices 09 and 10: Case X (T <sub>J</sub> ) = 119°C; Case Y (T <sub>J</sub> ) = 125.8°C	

1.4 Recommended operating conditions.

Case operating temperature range (T <sub>C</sub> ) 01-08 . . . . .	-55°C to +125°C
Case operating temperature range (T <sub>C</sub> ) 09-10 . . . . .	-40°C to +110°C
Supply voltage, (V <sub>CC</sub> ) . . . . .	4.75 V dc ≤ V <sub>CC</sub> ≤ 5.25 V dc

1.5 Digital logic testing for device classes Q and V.

Fault coverage measurement of manufacturing logic tests (MIL-STD-883, test method 5012) . . . . .	98.5 percent
---	--------------

2. APPLICABLE DOCUMENTS

2.1 Government specification, standards, and handbooks. The following specification, standards, and handbooks form a part of this drawing to the extent specified herein. Unless otherwise specified, the issues of these documents are those listed in the issue of the Department of Defense Index of Specifications and Standards (DoDISS) and supplement thereto, cited in the solicitation.

SPECIFICATION

MILITARY

MIL-PRF-38535 - Integrated Circuits, Manufacturing, General Specification for.

STANDARDS

MILITARY

- MIL-STD-883 - Test Methods and Procedures for Microelectronics.
- MIL-STD-973 - Configuration Management.
- MIL-STD-1835 - Microcircuit Case Outlines.

HANDBOOKS

MILITARY

- MIL-HDBK-103 - List of Standard Microcircuit Drawings (SMD's).
- MIL-HDBK-780 - Standard Microcircuit Drawings.

(Unless otherwise indicated, copies of the specification, standards, and handbooks are available from the Standardization Document Order Desk, 700 Robbins Avenue, Building 4D, Philadelphia, PA 19111-5094.)

2.2 Non Government publications. The following document(s) for a part of this document to the extent specified herein. Unless otherwise specified, the issues of the documents which are DOD adopted are those listed in the issue of the DoDISS cited in the solicitation. Unless otherwise specified, the issues of documents not listed in the DoDISS are the issues of the documents cited in the solicitation.

2/ Stresses above the absolute maximum rating may cause permanent damage to the device. Extended operation at the maximum levels may degrade performance and affect reliability.

<b>STANDARD MICROCIRCUIT DRAWING DEFENSE SUPPLY CENTER COLUMBUS COLUMBUS, OHIO 43216-5000</b>	<b>SIZE A</b>		<b>5962-93105</b>
		<b>REVISION LEVEL C</b>	<b>SHEET 3</b>

INSTITUTE OF ELECTRICAL AND ELECTRONICS ENGINEERS (IEEE)

IEEE Standard 1149.1 - IEEE Standard Test Access Port and Boundary Scan Architecture.

(Applications for copies should be addressed to the Institute of Electrical and Electronics Engineers, 445 Hoes Lane, Piscataway, NJ 08854-4150.)

(Non-Government standards and other publications are normally available from the organizations that prepare or distribute the documents. These documents may also be available in or through libraries or other informational services.)

2.3 Order of precedence. In the event of a conflict between the text of this drawing and the references cited herein, the text of this drawing takes precedence. Nothing in this document, however, supersedes applicable laws and regulations unless a specific exemption has been obtained.

3. REQUIREMENTS

3.1 Item requirements. The individual item requirements for device classes Q and V shall be in accordance with MIL-PRF-38535 and as specified herein or as modified in the device manufacturer's Quality Management (QM) plan. The modification in the QM plan shall not affect the form, fit, or function as described herein. The individual item requirements for device class M shall be in accordance with MIL-PRF-38535, appendix A for non-JAN class level B devices and as specified herein.

3.2 Design, construction, and physical dimensions. The design, construction, and physical dimensions shall be as specified in MIL-PRF-38535 and herein for device classes N, Q and V or MIL-PRF-38535, appendix A and herein for device class M.

3.2.1 Case outline(s). The case outline(s) shall be in accordance with 1.2.4 herein and figure 1.

3.2.2 Terminal connections. The terminal connections shall be as specified on figure 2.

3.2.3 Block diagram. The block diagram shall be as specified on figure 3.

3.2.4 Boundary Scan Instruction Codes. For device 03 - 10 the boundary scan instruction codes shall be as specified on figure 4.

3.2.5 Timing waveforms. The timing waveforms shall be as specified on figure 5.

3.2.6 Radiation exposure circuit. The radiation exposure circuit shall be as specified when available.

3.3 Electrical performance characteristics and postirradiation parameter limits. Unless otherwise specified herein, the electrical performance characteristics and postirradiation parameter limits are as specified in table I and shall apply over the full case operating temperature range.

3.4 Electrical test requirements. The electrical test requirements shall be the subgroups specified in table II. The electrical tests for each subgroup are defined in table I.

3.5 Marking. The part shall be marked with the PIN listed in 1.2 herein. In addition, the manufacturer's PIN may also be marked as listed in MIL-HDBK-103. For packages where marking of the entire SMD PIN number is not feasible due to space limitations, the manufacturer has the option of not marking the "5962-" on the device. For RHA product using this option, the RHA designator shall still be marked. Marking for device classes N, Q and V shall be in accordance with MIL-PRF-38535. Marking for device class M shall be in accordance with MIL-PRF-38535, appendix A.

3.5.1 Certification/compliance mark. The certification mark for device classes N, Q and V shall be a "QML" or "Q" as required in MIL-PRF-38535. The compliance mark for device class M shall be a "C" as required in MIL-PRF-38535, appendix A.

3.6 Certificate of compliance. For device classes N, Q and V, a certificate of compliance shall be required from a QML-38535 listed manufacturer in order to supply to the requirements of this drawing (see 6.6.1 herein). For device class M, a certificate of compliance shall be required from a manufacturer in order to be listed as an approved source of supply in MIL-HDBK-103 (see 6.6.2 herein). The certificate of compliance submitted to DSCC-VA prior to listing as an approved source of supply for this drawing shall affirm that the manufacturer's product meets, for device classes N, Q and V, the requirements of MIL-PRF-38535 and herein or for device class M, the requirements of MIL-PRF-38535, appendix A and herein.

3.7 Certificate of conformance. A certificate of conformance as required for device classes N, Q and V in MIL-PRF-38535 or for device class M in MIL-PRF-38535, appendix A shall be provided with each lot of microcircuits delivered to this drawing.

STANDARD MICROCIRCUIT DRAWING DEFENSE SUPPLY CENTER COLUMBUS COLUMBUS, OHIO 43216-5000	SIZE A		5962-93105
		REVISION LEVEL C	SHEET 4

TABLE I. Electrical performance characteristics.

Test	Symbol	Conditions 1/ 4.75 V ≤ V <sub>CC</sub> ≤ 5.25 V unless otherwise specified	Group A subgroups	Device type	Limits		Unit
					Min	Max	
Input low voltage	V <sub>IL</sub>	Frequency = 8 MHz 2/ 3/	1,2,3	All	-0.3 4/	0.8	V
Input high voltage	V <sub>IH</sub>	Frequency = 8 MHz 2/ 3/	1,2,3	All	2.0	V <sub>CC</sub> +0.3 4/	V
Output low voltage 3/ 5/	V <sub>OL</sub>	I <sub>OL</sub> = 4.0 mA	1,2,3	01,03, 05,07, 09		0.45	V
		I <sub>OL</sub> = 5.0 mA		02,04, 06,08, 10			
Output high voltage 5/	V <sub>OH</sub>	I <sub>OH</sub> = -1.0 mA	1,2,3	01,03, 05,07 09	2.4		V
		I <sub>OH</sub> = -0.9 mA		02,04, 06,08, 10			
Input leakage current	I <sub>LI</sub>	V <sub>IN</sub> = GND and V <sub>CC</sub>	1,2,3	All	-15	+15	μA
Input leakage current	I <sub>IH</sub>	V <sub>IN</sub> = 2.4 V 6/	1,2,3	All		200	μA
Input leakage current	I <sub>IL</sub>	V <sub>IN</sub> = 0.45 V 7/	1,2,3	All		-400	μA
Output leakage current	I <sub>LO</sub>	V <sub>IN</sub> = GND and V <sub>CC</sub>	1,2,3	All	-15	+15	μA
Supply current	I <sub>CC</sub>	V <sub>CC</sub> = V <sub>CC</sub> MAX	1,2,3	01,05		700	mA
				02,06		900	
				03,07		950	
				09			
				04,08 10		1200	
CLK input capacitance	C <sub>CLK</sub>	Frequency = 1 MHz See 4.4.1.c	4	01,02, 05,07, 09		20	pF
				03,04, 06,08, 10		15	
Input capacitance	C <sub>IN</sub>	Frequency = 1 MHz See 4.4.1.c	4	01,02, 05,07, 09		20	pF
				03,04, 06,08, 10		13	

See footnotes at end of table.

<b>STANDARD MICROCIRCUIT DRAWING DEFENSE SUPPLY CENTER COLUMBUS COLUMBUS, OHIO 43216-5000</b>	<b>SIZE A</b>		<b>5962-93105</b>
		<b>REVISION LEVEL C</b>	<b>SHEET 5</b>

TABLE I. Electrical performance characteristics.

Test	Symbol	Conditions 1/ 4.75 V ≤ V <sub>CC</sub> ≤ 5.25 V unless otherwise specified	Group A subgroups	Device type	Limits		Unit
					Min	Max	
Input/output capacitance	C <sub>0</sub>	Frequency = 1 MHz See 4.4.1.c	4	01,02, 05,07,09 03,04, 06,08,10		20 17	pF
Functional test		See 4.4.1.b	7,8	ALL			
System clock period 8/	t <sub>1</sub>	See figure 5	9,10,11	01,03,05,07 09 02,04,06,08 10	40 30	125 125	ns
System clock high time	t <sub>2</sub>	at 2.0 V See figure 5	9,10,11	01,03,05,07 09 02,04,06,08 10	14 11		ns
System clock low time	t <sub>3</sub>	at 0.8 V See figure 5	9,10,11	01,03,05,07 09 02,04,06,08 10	14 11		ns
System clock fall time 2/	t <sub>4</sub>	2.0 V to 0.8 V See figure 5	9,10,11	01,03,05,07 09 02,04,06,08 10		4 3	ns
System clock rise time 2/	t <sub>5</sub>	0.8 V to 2.0 V See figure 5	9,10,11	01,03,05,07 09 02,04,06,08 10		4 3	ns
A2-A31,PWT,PCD,BEO-3#,M/10#, D/C#,W/R#,ADS#,LOCK#, FERR#,BREQ,HLDA VALID DELAY	t <sub>6</sub>	See figure 5	9,10,11	01 02, 03,05,07,09 04,06,08,10	2 2 2 2	22 16 19 14	ns
A2-A31,PWT,PCD,BEO-3#,M/10#, D/C#,W/R#,ADS#,LOCK# FLOAT DELAY	t <sub>7</sub>	See figure 5	9,10,11	01 02, 03,05,07,09 04,06,08,10		30 20 28 20	ns
PCHK# VALID DELAY	t <sub>8</sub>	See figure 5	9,10,11	01 02, 03,05,07,09 04,06,08,10	2 2 2 2	27 22 24 14	ns

See footnotes at end of table.

STANDARD MICROCIRCUIT DRAWING DEFENSE SUPPLY CENTER COLUMBUS COLUMBUS, OHIO 43216-5000	SIZE <b>A</b>		<b>5962-93105</b>
		REVISION LEVEL C	SHEET <b>6</b>

TABLE I. Electrical performance characteristics.

Test	Symbol	Conditions 1/ 4.75 V ≤ V <sub>CC</sub> ≤ 5.25 V unless otherwise specified	Group A subgroups	Device type	Limits		Unit
					Min	Max	
BLAST#, PLOCK# VALID DELAY	t <sub>8a</sub>	See figure 5	9,10,11	01 02, 03,05,07,09 04,06,08,10	2 2 2 2	27 20 24 14	ns
BLAST#, PLOCK# FLOAT DELAY	t <sub>9</sub>	See figure 5	9,10,11	01 02, 03,05,07,09 04,06,08,10		30 20 28 20	ns
D0-D31,DPO-3 WRITE DATA VALID DELAY	t <sub>10</sub>	See figure 5	9,10,11	01 02 03,05,07,09 04,06,08,10	2 2 2 2	22 18 20 14	ns
D0-D31,DPO-3 WRITE DATA FLOAT DELAY 4/	t <sub>11</sub>	See figure 5	9,10,11	01 02 03,05,07,09 04,06,08,10		30 20 28 20	ns
EADS# SETUP TIME	t <sub>12</sub>	See figure 5	9,10,11	01,03,05,07 09 02,04,06,08 10	8 5		ns
EADS# SETUP TIME	t <sub>13</sub>	See figure 5	9,10,11	All	3		ns
KEN#,BS16#,BS8# SETUP TIME	t <sub>14</sub>	See figure 5	9,10,11	01,03,05,07 09 02,04,06,08 10	8 5		ns
KEN#,BS16#,BS8# HOLD TIME	t <sub>15</sub>	See figure 5	9,10,11	All	3		ns
RDY#,BRDY# SETUP TIME	t <sub>16</sub>	See figure 5	9,10,11	01,03,05,07 09 02,04,06,08 10	8 5		ns
RDY#,BRDY# HOLD TIME	t <sub>17</sub>	See figure 5	9,10,11	ALL	3		ns
HOLD,AHOLD SETUP TIME	t <sub>18</sub>	See figure 5	9,10,11	01 02,04,06,08 10 03,05,07,09	10 6 10 8		ns

See footnotes at end of table.

<b>STANDARD MICROCIRCUIT DRAWING DEFENSE SUPPLY CENTER COLUMBUS COLUMBUS, OHIO 43216-5000</b>	<b>SIZE A</b>		<b>5962-93105</b>
		<b>REVISION LEVEL C</b>	<b>SHEET 7</b>

TABLE I. Electrical performance characteristics.

Test	Symbol	Conditions 1/ 4.75 V ≤ V <sub>CC</sub> ≤ 5.25 V unless otherwise specified	Group A subgroups	Device type	Limits		Unit
					Min	Max	
BOFF# SETUP TIME	t <sub>18a</sub>	See figure 5	9,10,11	01 02 03,05,07,09 04,06,08,10	10 8 8 7		ns
HOLD,AHOLD,BOFF# HOLD TIME	t <sub>19</sub>	See figure 5	9,10,11	All	3		ns
RESET, FLUSH#, A20M#,NMI, INTR,IGNNE# SETUP TIME	t <sub>20</sub>	See figure 5	9,10,11	01 02 03,05,07,09 04,06,08,10	10 5 8 5		ns
RESET, FLUSH#, A20M#,NMI, INTR,IGNNE# SETUP TIME	t <sub>21</sub>	See figure 5	9,10,11	All	3		ns
D0-D31,DPO-3,A4-A31 READ SETUP TIME	t <sub>22</sub>	See figure 5	9,10,11	All	5		ns
D0-D31,DPO-3,A4-A31 READ HOLD TIME	t <sub>23</sub>	See figure 5	9,10,11	All	3		ns
TCK frequency	t <sub>24</sub>	See figure 6 1X clock	9,10,11	All		8	MHz
TCK period	t <sub>25</sub>	See figure 6	9,10,11	All	125		ns
TCK high time	t <sub>26</sub>	See figure 6 V <sub>IN</sub> = 2.0 V	9,10,11	01 - 02 03 - 10	10 40		ns
TCK low time	t <sub>27</sub>	See figure 6 V <sub>IN</sub> = 0.8 V	9,10,11	01 - 02 03 - 10	10 40		ns
TCK rise time	t <sub>28</sub>	See figure 6 2.0 V to 0.8 V	9,10,11	01 - 02 03 - 10		4 8	ns
TCK fall time	t <sub>29</sub>	See figure 6 0.8 V to 2.0 V	9,10,11	01 - 02 03 - 10		4 8	ns
TDI, TMS setu time	t <sub>30</sub>	See figure 6	9,10,11	All	8		ns
TDI, TMS hold time	t <sub>31</sub>	See figure 6	9,10,11	01 - 02 03 - 10	7 10		ns
TDO valid delay	t <sub>32</sub>	See figure 6	9,10,11	01 - 02 03 - 10	2 2	25 30	ns

See footnotes at end of table.

<b>STANDARD MICROCIRCUIT DRAWING DEFENSE SUPPLY CENTER COLUMBUS COLUMBUS, OHIO 43216-5000</b>	<b>SIZE A</b>		<b>5962-93105</b>
		<b>REVISION LEVEL C</b>	<b>SHEET 8</b>



TABLE I. Electrical performance characteristics.

Test	Symbol	Conditions 1/ 4.75 V ≤ V <sub>CC</sub> ≤ 5.25 V unless otherwise specified	Group A subgroups	Device type	Limits		Unit
					Min	Max	
TDO float delay	t <sub>33</sub>	See figure 6	9,10,11	All		36	ns
All outputs (non-test) valid delay	t <sub>34</sub>	See figure 6	9,10,11	01 - 02 03 - 10	2 2	25 30	ns
All outputs (non-test) float delay	t <sub>35</sub>	See figure 6	9,10,11	All		36	ns
All inputs (non-test) setup time	t <sub>36</sub>	See figure 6	9,10,11	All	8		ns
All inputs (non-test) hold time	t <sub>37</sub>	See figure 6	9,10,11	01 - 02 03 - 10	7 10		ns

- 1/ All testing to be performed using worst-case test conditions unless otherwise specified. The # sign indicates an active low signal. Temperature range shall be as follows: device types 01-08, case temperature -55°C to +125°C, device types 09-10, case temperature -40°C to +110°C.
- 2/ Frequency stated is system frequency, not internal CPU frequency.
- 3/ Test pins (TCK, TDI, TCO, TMS) are exceptions, These pins are tested and guaranteed to the following limits: V<sub>IL</sub> = 0 V, V<sub>IH</sub> = 3 V, V<sub>OL</sub> = V<sub>OH</sub> = 1.5 V, I<sub>OL</sub> = I<sub>OH</sub> = 0 mA.
- 4/ Guaranteed by design characterization but not tested.
- 5/ Actual value tested may vary due to test hardware limitations, however, specified value is guaranteed.
- 6/ Parameter is for input pins with internal pulldown resistors.
- 7/ Parameter is for input pins with internal pullup resistors.
- 8/ Frequencies specified are system interface frequencies. Internal CPU frequency for device type 03, 07 is 50 MHz and for device types 04, 08 is 66 MHz.
- 9/ Parameter is not tested due to test hardware limitations, however, specified value is guaranteed.

<b>STANDARD MICROCIRCUIT DRAWING DEFENSE SUPPLY CENTER COLUMBUS COLUMBUS, OHIO 43216-5000</b>	<b>SIZE A</b>		<b>5962-93105</b>
		<b>REVISION LEVEL C</b>	<b>SHEET 9</b>

Case Y

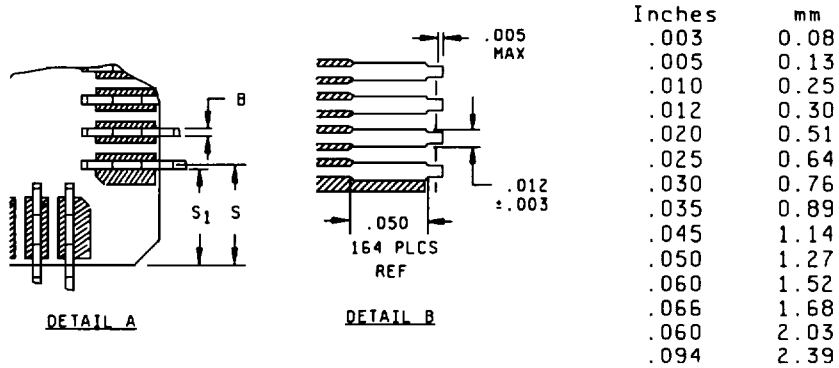
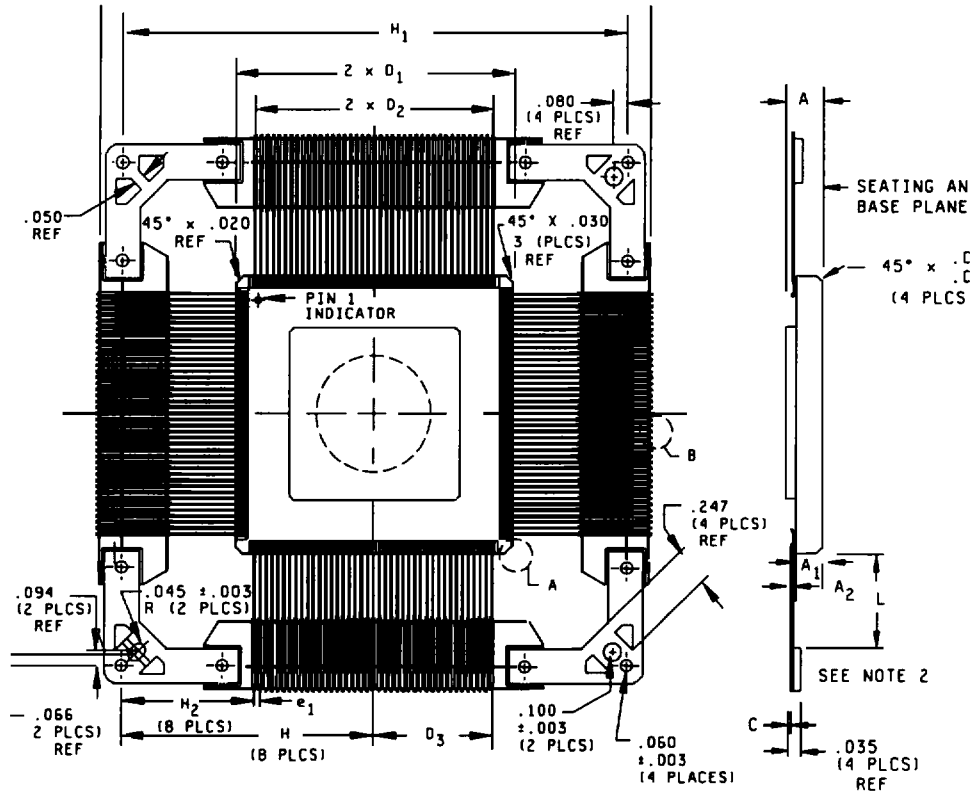

- NOTES:  
 1. Dimensions are in inches.  
 2. Metric equivalents are given for general information only.

FIGURE 1. Case outline.

STANDARD MICROCIRCUIT DRAWING DEFENSE SUPPLY CENTER COLUMBUS COLUMBUS, OHIO 43216-5000	SIZE <b>A</b>		5962-93105
		REVISION LEVEL C	SHEET 10

Case Y

Symbol	Millimeters			Inches		
	Min	Max	Notes	Min	Max	Notes
A	2.23	2.92	Solid lid	0.088	0.115	Solid lid
A <sub>1</sub>	1.96	2.39		0.077	0.094	
B	0.20	0.25		0.008	0.010	
C	0.10	0.20		0.004	0.008	
D	63.50	64.01		2.500	2.520	
D <sub>1</sub>	33.65	34.16		1.325	1.345	
D <sub>2</sub>	30.48 Basic			1.200 Basic		
e <sub>1</sub>	0.58	0.69		0.023	0.027	
H	29.21 Basic			1.150 Basic		
H <sub>1</sub>	58.42 Basic			2.30 Basic		
H <sub>2</sub>	19.05 Basic			0.750 Basic		
L	9.27	10.03		0.365	0.395	
N	196			196		
S	1.270	2.03	Reference	0.050	0.080	Reference
S <sub>1</sub>	1.14	1.93	Reference	0.045	0.076	Reference

FIGURE 1. Case outline - Continued.

<p>STANDARD MICROCIRCUIT DRAWING DEFENSE SUPPLY CENTER COLUMBUS COLUMBUS, OHIO 43216-5000</p>	<p>SIZE <b>A</b></p>		<p>5962-93105</p>
		<p>REVISION LEVEL C</p>	<p>SHEET 11</p>

Device types 01 and 02

Case X

	1	2	3	4	5	6	7	8	9	10	11	12	13	14	15	16	17	
S	A27	A26	A23	NC	A14	V <sub>SS</sub>	A12	V <sub>SS</sub>	V <sub>SS</sub>	V <sub>SS</sub>	V <sub>SS</sub>	V <sub>SS</sub>	A10	V <sub>SS</sub>	A6	A4	AD5#	S
	○	○	○	○	○	○	○	○	○	○	○	○	○	○	○	○	○	
R	A28	A25	V <sub>CC</sub>	V <sub>SS</sub>	A18	V <sub>CC</sub>	A15	V <sub>CC</sub>	V <sub>CC</sub>	V <sub>CC</sub>	V <sub>CC</sub>	A11	A8	V <sub>CC</sub>	A3	BLAST#	NC	R
	○	○	○	○	○	○	○	○	○	○	○	○	○	○	○	○	○	
D	A31	V <sub>SS</sub>	A17	A19	A21	A24	A22	A20	A16	A13	A9	A5	A7	A2	BREQ	PLDCK#	PCHK#	D
	○	○	○	○	○	○	○	○	○	○	○	○	○	○	○	○	○	
P	DP0	A29	DA30											HLDA	V <sub>CC</sub>	V <sub>SS</sub>		P
	○	○	○											○	○	○		
N	D2	D1	DPD											LOCK#	M/10#	W/R#		N
	○	○	○											○	○	○		
M	V <sub>SS</sub>	V <sub>CC</sub>	D4											D/C#	V <sub>CC</sub>	V <sub>SS</sub>		M
	○	○	○											○	○	○		
L	V <sub>SS</sub>	D6	D7											PWT	V <sub>CC</sub>	V <sub>SS</sub>		L
	○	○	○											○	○	○		
K	V <sub>SS</sub>	V <sub>CC</sub>	D14											BE0#	V <sub>CC</sub>	V <sub>SS</sub>		K
	○	○	○											○	○	○		
J	V <sub>CC</sub>	D5	D16											BE2#	BE1#	PCD		J
	○	○	○											○	○	○		
H	V <sub>SS</sub>	D3	DP2											BRDY#	V <sub>CC</sub>	V <sub>SS</sub>		H
	○	○	○											○	○	○		
G	V <sub>SS</sub>	V <sub>CC</sub>	D12											NC	V <sub>CC</sub>	V <sub>SS</sub>		G
	○	○	○											○	○	○		
F	DP1	D8	D15											KEN#	RDY#	BE3#		F
	○	○	○											○	○	○		
E	V <sub>SS</sub>	V <sub>CC</sub>	D10											HOLD	V <sub>CC</sub>	V <sub>SS</sub>		E
	○	○	○											○	○	○		
D	D9	D13	D17											A2DM#	BSB#	BOFF#		D
	○	○	○											○	○	○		
C	D11	D18	CLK	V <sub>CC</sub>	V <sub>CC</sub>	D27	D26	D28	D30	NC	NC	NC	NC	FERR#	FLUSH#	RESET	BS16#	C
	○	○	○	○	○	○	○	○	○	○	○	○	○	○	○	○	○	
B	D19	D21	V <sub>SS</sub>	V <sub>SS</sub>	V <sub>SS</sub>	D25	V <sub>CC</sub>	D31	V <sub>CC</sub>	NC	V <sub>CC</sub>	NC	NC	NC	NMI	NC	EADS#	B
	○	○	○	○	○	○	○	○	○	○	○	○	○	○	○	○	○	
A	D20	D22	NC	D23	DP3	D24	V <sub>SS</sub>	D29	V <sub>SS</sub>	NC	V <sub>SS</sub>	NC	NC	NC	IGNNE#	INTR	AHDLD	A
	○	○	○	○	○	○	○	○	○	○	○	○	○	○	○	○	○	

BOTTOM VIEW

Note:  
The # sign denotes an active low pin.

Figure 2. Terminal connections.

<b>STANDARD MICROCIRCUIT DRAWING DEFENSE SUPPLY CENTER COLUMBUS COLUMBUS, OHIO 43216-5000</b>	<b>SIZE A</b>		<b>5962-93105</b>
		<b>REVISION LEVEL C</b>	<b>SHEET 12</b>

Device types 03 and 04

Case X

	1	2	3	4	5	6	7	8	9	10	11	12	13	14	15	16	17	
S	A27	A26	A23	NC	A14	V <sub>SS</sub>	A12	V <sub>SS</sub>	V <sub>SS</sub>	V <sub>SS</sub>	V <sub>SS</sub>	V <sub>SS</sub>	A10	V <sub>SS</sub>	A6	A4	ADS=	S
	O	O	O	O	O	O	O	O	O	O	O	O	O	O	O	O	O	
R	A28	A25	V <sub>CC</sub>	V <sub>SS</sub>	A18	V <sub>CC</sub>	A15	V <sub>CC</sub>	V <sub>CC</sub>	V <sub>CC</sub>	V <sub>CC</sub>	A11	A8	V <sub>CC</sub>	A3	BLAST=	NC	R
	O	O	O	O	O	O	O	O	O	O	O	O	O	O	O	O	O	
D	A31	V <sub>SS</sub>	A17	A19	A21	A24	A22	A20	A16	A13	A9	A5	A7	A2	BRED	PLOCK=	PCHK=	D
	O	O	O	O	O	O	O	O	O	O	O	O	O	O	O	O	O	
P	DO	A29	A30												HLDA	V <sub>CC</sub>	V <sub>SS</sub>	P
	O	O	O												O	O	O	
N	D2	D1	DPO												LOCK=	M/10=	W/R=	N
	O	O	O												O	O	O	
M	V <sub>SS</sub>	V <sub>CC</sub>	D4												D/C=	V <sub>CC</sub>	V <sub>SS</sub>	M
	O	O	O												O	O	O	
L	V <sub>SS</sub>	D6	D7												PWT	V <sub>CC</sub>	V <sub>SS</sub>	L
	O	O	O												O	O	O	
K	V <sub>SS</sub>	V <sub>CC</sub>	D14												BEO=	V <sub>CC</sub>	V <sub>SS</sub>	K
	O	O	O												O	O	O	
J	V <sub>CC</sub>	D5	D16												BE2=	BE1=	PCD	J
	O	O	O												O	O	O	
H	V <sub>SS</sub>	D3	DP2												BRDY=	V <sub>CC</sub>	V <sub>SS</sub>	H
	O	O	O												O	O	O	
G	V <sub>SS</sub>	V <sub>CC</sub>	D12												NC	V <sub>CC</sub>	V <sub>SS</sub>	G
	O	O	O												O	O	O	
F	DP1	D8	D15												KEN=	ROY=	BES=	F
	O	O	O												O	O	O	
E	V <sub>SS</sub>	V <sub>CC</sub>	D10												HOLD	V <sub>CC</sub>	V <sub>SS</sub>	E
	O	O	O												O	O	O	
D	D9	D13	D17												A20M=	BS8=	BOFF=	D
	O	O	O												O	O	O	
C	D11	D18	CLK	V <sub>CC</sub>	V <sub>CC</sub>	D27	D26	D28	D30	NC	NC	NC	NC	FERR=	FLUSH=	RESET	BS16=	C
	O	O	O	O	O	O	O	O	O	O	O	O	O	O	O	O	O	
B	D19	D21	V <sub>SS</sub>	V <sub>SS</sub>	V <sub>SS</sub>	D25	V <sub>CC</sub>	D31	V <sub>CC</sub>	NC	V <sub>CC</sub>	NC	NC	THS	NMI	TDO	EADS=	B
	O	O	O	O	O	O	O	O	O	O	O	O	O	O	O	O	O	
A	D20	D22	TCK	D23	DP3	D24	V <sub>SS</sub>	D29	V <sub>SS</sub>	NC	V <sub>SS</sub>	NC	NC	TDI	IGNNE=	INTR	AHOLD	A
	O	O	O	O	O	O	O	O	O	O	O	O	O	O	O	O	O	

FIGURE 2. Terminal connections. - Continued

STANDARD MICROCIRCUIT DRAWING DEFENSE SUPPLY CENTER COLUMBUS COLUMBUS, OHIO 43216-5000	SIZE <b>A</b>		<b>5962-93105</b>
		REVISION LEVEL C	SHEET <b>13</b>

Device types 05, 06, 07, 08, 09 and 10

Case X

	1	2	3	4	5	6	7	8	9	10	11	12	13	14	15	16	17		
S	A27	A26	A23	NC	A14	V <sub>SS</sub>	A12	V <sub>SS</sub>	V <sub>SS</sub>	V <sub>SS</sub>	V <sub>SS</sub>	V <sub>SS</sub>	A10	V <sub>SS</sub>	A6	A4	ADS=	S	
	○	○	○	○	○	○	○	○	○	○	○	○	○	○	○	○	○	○	
R	A28	A25	V <sub>CC</sub>	V <sub>SS</sub>	A18	V <sub>CC</sub>	A15	V <sub>CC</sub>	V <sub>CC</sub>	V <sub>CC</sub>	V <sub>CC</sub>	A11	A8	V <sub>CC</sub>	A3	BLAST=	NC	R	
	○	○	○	○	○	○	○	○	○	○	○	○	○	○	○	○	○	○	
Q	A31	V <sub>SS</sub>	A17	A19	A21	A24	A22	A20	A16	A13	A9	A5	A7	A2	BRED	PLOCK=	PCHK=	Q	
	○	○	○	○	○	○	○	○	○	○	○	○	○	○	○	○	○	○	
P	D0	A29	A30												HLDA	V <sub>CC</sub>	V <sub>SS</sub>	P	
	○	○	○												○	○	○		
N	D2	D1	DP0												LOCK=	M/10=	M/R=	N	
	○	○	○												○	○	○		
H	V <sub>SS</sub>	V <sub>CC</sub>	D4												D/C=	V <sub>CC</sub>	V <sub>SS</sub>	H	
	○	○	○												○	○	○		
L	V <sub>SS</sub>	D6	D7												PWT	V <sub>CC</sub>	V <sub>SS</sub>	L	
	○	○	○												○	○	○		
K	V <sub>SS</sub>	V <sub>CC</sub>	D14												BE0=	V <sub>CC</sub>	V <sub>SS</sub>	K	
	○	○	○												○	○	○		
J	V <sub>CC</sub>	D5	D16												BE2=	BE1=	PCD	J	
	○	○	○												○	○	○		
H	V <sub>SS</sub>	D3	DP2												BRDY=	V <sub>CC</sub>	V <sub>SS</sub>	H	
	○	○	○												○	○	○		
G	V <sub>SS</sub>	V <sub>CC</sub>	D12												STPCLK=	V <sub>CC</sub>	V <sub>SS</sub>	G	
	○	○	○												○	○	○		
F	DP1	D8	D15												KEN=	ROY=	BE3=	F	
	○	○	○												○	○	○		
E	V <sub>SS</sub>	V <sub>CC</sub>	D10												HOLD	V <sub>CC</sub>	V <sub>SS</sub>	E	
	○	○	○												○	○	○		
D	D9	D13	D17												A20M=	BSB=	BOFF=	D	
	○	○	○												○	○	○		
C	D11	D18	CLK	V <sub>CC</sub>	V <sub>CC</sub>	D27	D26	D28	D30	SRESET	NC	SMI <sub>ACT</sub> =	NC	FERR=	FLUSH=	RESET	BS16=	C	
	○	○	○	○	○	○	○	○	○	○	○	○	○	○	○	○	○	○	
B	D19	D21	V <sub>SS</sub>	V <sub>SS</sub>	V <sub>SS</sub>	D25	V <sub>CC</sub>	D31	V <sub>CC</sub>	SMI=	V <sub>CC</sub>	NC	NC	TMS	NMI	TDO	EADS=	B	
	○	○	○	○	○	○	○	○	○	○	○	○	○	○	○	○	○	○	
A	D20	D22	TCK	D23	DP3	D24	V <sub>SS</sub>	D29	V <sub>SS</sub>	NC	V <sub>SS</sub>	NC	NC	TDI	IGNME=	INTR	AHOLD	A	
	○	○	○	○	○	○	○	○	○	○	○	○	○	○	○	○	○	○	

Figure 2. Terminal connections - Continued

STANDARD MICROCIRCUIT DRAWING DEFENSE SUPPLY CENTER COLUMBUS COLUMBUS, OHIO 43216-5000	SIZE <b>A</b>		5962-93105
		REVISION LEVEL C	SHEET 14

Case outlines		Y									
Device types		01 and 02									
Terminal number	Terminal symbol	Terminal number	Terminal symbol	Terminal number	Terminal symbol	Terminal number	Terminal symbol	Terminal number	Terminal symbol	Terminal number	Terminal symbol
1	D21	34	N/C	67	W/R#	100	BLAST#	133	V <sub>SS</sub>	166	V <sub>SS</sub>
2	D22	35	V <sub>SS</sub>	68	V <sub>SS</sub>	101	ADS#	134	N/C	167	D5
3	D23	36	N/C	69	HLDA	102	A2	135	V <sub>CC</sub>	168	V <sub>CC</sub>
4	DP3	37	V <sub>CC</sub>	70	V <sub>CC</sub>	103	A3	136	N/C	169	D6
5	D24	38	N/C	71	CLK	104	A4	137	V <sub>SS</sub>	170	V <sub>SS</sub>
6	D25	39	V <sub>SS</sub>	72	V <sub>SS</sub>	105	V <sub>SS</sub>	138	A18	171	D7
7	V <sub>SS</sub>	40	N/C	73	V <sub>SS</sub>	106	A5	139	V <sub>CC</sub>	172	V <sub>CC</sub>
8	D26	41	V <sub>CC</sub>	74	V <sub>CC</sub>	107	V <sub>CC</sub>	140	A19	173	DP1
9	V <sub>CC</sub>	42	N/C	75	V <sub>CC</sub>	108	N/C	141	V <sub>SS</sub>	174	V <sub>SS</sub>
10	D27	43	V <sub>SS</sub>	76	V <sub>SS</sub>	109	V <sub>SS</sub>	142	A20	175	D8
11	V <sub>SS</sub>	44	N/C	77	N/C	110	A6	143	A21	176	V <sub>CC</sub>
12	D28	45	N/C	78	V <sub>CC</sub>	111	V <sub>CC</sub>	144	A22	177	D9
13	V <sub>CC</sub>	46	NMI	79	N/C	112	A7	145	A23	178	V <sub>SS</sub>
14	D29	47	INTR	80	V <sub>SS</sub>	113	V <sub>SS</sub>	146	A24	179	D10
15	V <sub>SS</sub>	48	FLUSH#	81	AHOLD	114	A8	147	A25	180	V <sub>CC</sub>
16	D30	49	RESET	82	V <sub>CC</sub>	115	V <sub>CC</sub>	148	A26	181	D11
17	V <sub>CC</sub>	50	A20M#	83	HOLD	116	A9	149	A27	182	V <sub>SS</sub>
18	D31	51	EADS#	84	V <sub>SS</sub>	117	V <sub>SS</sub>	150	A28	183	D12
19	V <sub>SS</sub>	52	PCD	85	KEN#	118	A10	151	A29	184	V <sub>CC</sub>
20	IGNNE#	53	PWT	86	V <sub>CC</sub>	119	V <sub>CC</sub>	152	A30	185	D13
21	V <sub>CC</sub>	54	D/C#	87	RDY#	120	A11	153	A31	186	V <sub>SS</sub>
22	N/C	55	M/IO#	88	V <sub>SS</sub>	121	V <sub>SS</sub>	154	V <sub>SS</sub>	187	D14
23	V <sub>SS</sub>	56	V <sub>SS</sub>	89	N/C	122	A12	155	DP0	188	V <sub>CC</sub>
24	N/C	57	BE3#	90	V <sub>CC</sub>	123	V <sub>CC</sub>	156	V <sub>CC</sub>	189	D15
25	V <sub>CC</sub>	58	V <sub>CC</sub>	91	BS8#	124	A13	157	D0	190	V <sub>SS</sub>
26	FERR#	59	BE2#	92	V <sub>SS</sub>	125	V <sub>SS</sub>	158	V <sub>SS</sub>	191	DP2
27	V <sub>SS</sub>	60	V <sub>SS</sub>	93	BS16#	126	A14	159	D1	192	D16
28	N/C	61	BE1#	94	BOFF#	127	V <sub>CC</sub>	160	V <sub>CC</sub>	193	D17
29	V <sub>CC</sub>	62	V <sub>CC</sub>	95	BRDY#	128	A15	161	D2	194	D18
30	N/C	63	BEO	96	PCHK#	129	V <sub>SS</sub>	162	V <sub>SS</sub>	195	D19
31	V <sub>SS</sub>	64	V <sub>SS</sub>	97	N/C	130	A16	163	D3	196	D20
32	N/C	65	BREQ	98	LOCK#	131	V <sub>CC</sub>	164	V <sub>CC</sub>		
33	V <sub>CC</sub>	66	V <sub>CC</sub>	99	PLOCK#	132	A17	165	D4		

FIGURE 2. Terminal connections - Continued.

<b>STANDARD MICROCIRCUIT DRAWING DEFENSE SUPPLY CENTER COLUMBUS COLUMBUS, OHIO 43216-5000</b>	<b>SIZE A</b>		<b>5962-93105</b>
		<b>REVISION LEVEL C</b>	<b>SHEET 15</b>

Case outlines		Y									
Device types		03 and 04									
Terminal number	Terminal symbol	Terminal number	Terminal symbol	Terminal number	Terminal symbol	Terminal number	Terminal symbol	Terminal number	Terminal symbol	Terminal number	Terminal symbol
1	D21	34	N/C	67	W/R#	100	BLAST#	133	V <sub>SS</sub>	166	V <sub>SS</sub>
2	D22	35	V <sub>SS</sub>	68	V <sub>SS</sub>	101	ADS#	134	TDI	167	D5
3	D23	36	N/C	69	HLDA	102	A2	135	V <sub>CC</sub>	168	V <sub>CC</sub>
4	DP3	37	V <sub>CC</sub>	70	V <sub>CC</sub>	103	A3	136	TMS	169	D6
5	D24	38	N/C	71	CLK	104	A4	137	V <sub>SS</sub>	170	V <sub>SS</sub>
6	D25	39	V <sub>SS</sub>	72	V <sub>SS</sub>	105	V <sub>SS</sub>	138	A18	171	D7
7	V <sub>SS</sub>	40	N/C	73	V <sub>SS</sub>	106	A5	139	V <sub>CC</sub>	172	V <sub>CC</sub>
8	D26	41	V <sub>CC</sub>	74	V <sub>CC</sub>	107	V <sub>CC</sub>	140	A19	173	DP1
9	V <sub>CC</sub>	42	N/C	75	V <sub>CC</sub>	108	N/C	141	V <sub>SS</sub>	174	V <sub>SS</sub>
10	D27	43	V <sub>SS</sub>	76	V <sub>SS</sub>	109	V <sub>SS</sub>	142	A20	175	D8
11	V <sub>SS</sub>	44	N/C	77	N/C	110	A6	143	A21	176	V <sub>CC</sub>
12	D28	45	N/C	78	V <sub>CC</sub>	111	V <sub>CC</sub>	144	A22	177	D9
13	V <sub>CC</sub>	46	NMI	79	TCK	112	A7	145	A23	178	V <sub>SS</sub>
14	D29	47	INTR	80	V <sub>SS</sub>	113	V <sub>SS</sub>	146	A24	179	D10
15	V <sub>SS</sub>	48	FLUSH#	81	AHOLD	114	A8	147	A25	180	V <sub>CC</sub>
16	D30	49	RESET	82	V <sub>CC</sub>	115	V <sub>CC</sub>	148	A26	181	D11
17	V <sub>CC</sub>	50	A20M#	83	HOLD	116	A9	149	A27	182	V <sub>SS</sub>
18	D31	51	EADS#	84	V <sub>SS</sub>	117	V <sub>SS</sub>	150	A28	183	D12
19	V <sub>SS</sub>	52	PCD	85	KEN#	118	A10	151	A29	184	V <sub>CC</sub>
20	IGNNE#	53	PWT	86	V <sub>CC</sub>	119	V <sub>CC</sub>	152	A30	185	D13
21	V <sub>CC</sub>	54	D/C#	87	RDY#	120	A11	153	A31	186	V <sub>SS</sub>
22	N/C	55	M/IO#	88	V <sub>SS</sub>	121	V <sub>SS</sub>	154	V <sub>SS</sub>	187	D14
23	V <sub>SS</sub>	56	V <sub>SS</sub>	89	N/C	122	A12	155	DP0	188	V <sub>CC</sub>
24	TDO	57	BE3#	90	V <sub>CC</sub>	123	V <sub>CC</sub>	156	V <sub>CC</sub>	189	D15
25	V <sub>CC</sub>	58	V <sub>CC</sub>	91	BS8#	124	A13	157	D0	190	V <sub>SS</sub>
26	FERR#	59	BE2#	92	V <sub>SS</sub>	125	V <sub>SS</sub>	158	V <sub>SS</sub>	191	DP2
27	V <sub>SS</sub>	60	V <sub>SS</sub>	93	BS16#	126	A14	159	D1	192	D16
28	N/C	61	BE1#	94	BOFF#	127	V <sub>CC</sub>	160	V <sub>CC</sub>	193	D17
29	V <sub>CC</sub>	62	V <sub>CC</sub>	95	BRDY#	128	A15	161	D2	194	D18
30	N/C	63	BEO	96	PCHK#	129	V <sub>SS</sub>	162	V <sub>SS</sub>	195	D19
31	V <sub>SS</sub>	64	V <sub>SS</sub>	97	N/C	130	A16	163	D3	196	D20
32	N/C	65	BREQ	98	LOCK#	131	V <sub>CC</sub>	164	V <sub>CC</sub>		
33	V <sub>CC</sub>	66	V <sub>CC</sub>	99	PLOCK#	132	A17	165	D4		

FIGURE 2. Terminal connections - Continued.

<b>STANDARD MICROCIRCUIT DRAWING DEFENSE SUPPLY CENTER COLUMBUS COLUMBUS, OHIO 43216-5000</b>	<b>SIZE A</b>		<b>5962-93105</b>
		<b>REVISION LEVEL C</b>	<b>SHEET 16</b>



Case outlines	Y										
Device types	05, 06, 07, 08, 09, and 10										
Terminal number	Terminal symbol	Terminal number	Terminal symbol	Terminal number	Terminal symbol	Terminal number	Terminal symbol	Terminal number	Terminal symbol	Terminal number	Terminal symbol
1	D21	34	SMIACT#	67	W/R#	100	BLAST#	133	V <sub>SS</sub>	166	V <sub>SS</sub>
2	D22	35	V <sub>SS</sub>	68	V <sub>SS</sub>	101	ADS#	134	TDI	167	D5
3	D23	36	SRESET	69	HLDA	102	A2	135	V <sub>CC</sub>	168	V <sub>CC</sub>
4	DP3	37	V <sub>CC</sub>	70	V <sub>CC</sub>	103	A3	136	TMS	169	D6
5	D24	38	N/C	71	CLK	104	A4	137	V <sub>SS</sub>	170	V <sub>SS</sub>
6	D25	39	V <sub>SS</sub>	72	V <sub>SS</sub>	105	V <sub>SS</sub>	138	A18	171	D7
7	V <sub>SS</sub>	40	N/C	73	V <sub>SS</sub>	106	A5	139	V <sub>CC</sub>	172	V <sub>CC</sub>
8	D26	41	V <sub>CC</sub>	74	V <sub>CC</sub>	107	V <sub>CC</sub>	140	A19	173	DP1
9	V <sub>CC</sub>	42	N/C	75	V <sub>CC</sub>	108	N/C	141	V <sub>SS</sub>	174	V <sub>SS</sub>
10	D27	43	V <sub>SS</sub>	76	V <sub>SS</sub>	109	V <sub>SS</sub>	142	A20	175	D8
11	V <sub>SS</sub>	44	N/C	77	N/C	110	A6	143	A21	176	V <sub>CC</sub>
12	D28	45	N/C	78	V <sub>CC</sub>	111	V <sub>CC</sub>	144	A22	177	D9
13	V <sub>CC</sub>	46	NMI	79	TCK	112	A7	145	A23	178	V <sub>SS</sub>
14	D29	47	INTR	80	V <sub>SS</sub>	113	V <sub>SS</sub>	146	A24	179	D10
15	V <sub>SS</sub>	48	FLUSH#	81	AHOLD	114	A8	147	A25	180	V <sub>CC</sub>
16	D30	49	RESET	82	V <sub>CC</sub>	115	V <sub>CC</sub>	148	A26	181	D11
17	V <sub>CC</sub>	50	A20M#	83	HOLD	116	A9	149	A27	182	V <sub>SS</sub>
18	D31	51	EADS#	84	V <sub>SS</sub>	117	V <sub>SS</sub>	150	A28	183	D12
19	V <sub>SS</sub>	52	PCD	85	KEN#	118	A10	151	A29	184	V <sub>CC</sub>
20	IGNNE#	53	PWT	86	V <sub>CC</sub>	119	V <sub>CC</sub>	152	A30	185	D13
21	V <sub>CC</sub>	54	D/C#	87	RDY#	120	A11	153	A31	186	V <sub>SS</sub>
22	CLK#	55	M/IO#	88	V <sub>SS</sub>	121	V <sub>SS</sub>	154	V <sub>SS</sub>	187	D14
23	V <sub>SS</sub>	56	V <sub>SS</sub>	89	N/C	122	A12	155	DP0	188	V <sub>CC</sub>
24	TDO	57	BE3#	90	V <sub>CC</sub>	123	V <sub>CC</sub>	156	V <sub>CC</sub>	189	D15
25	V <sub>CC</sub>	58	V <sub>CC</sub>	91	BS8#	124	A13	157	D0	190	V <sub>SS</sub>
26	FERR#	59	BE2#	92	V <sub>SS</sub>	125	V <sub>SS</sub>	158	V <sub>SS</sub>	191	DP2
27	V <sub>SS</sub>	60	V <sub>SS</sub>	93	BS16#	126	A14	159	D1	192	D16
28	N/C	61	BE1#	94	BOFF#	127	V <sub>CC</sub>	160	V <sub>CC</sub>	193	D17
29	V <sub>CC</sub>	62	V <sub>CC</sub>	95	BRDY#	128	A15	161	D2	194	D18
30	SNI#	63	BEO	96	PCHK#	129	V <sub>SS</sub>	162	V <sub>SS</sub>	195	D19
31	V <sub>SS</sub>	64	V <sub>SS</sub>	97	N/C	130	A16	163	D3	196	D20
32	N/C	65	BREQ	98	LOCK#	131	V <sub>CC</sub>	164	V <sub>CC</sub>		
33	V <sub>CC</sub>	66	V <sub>CC</sub>	99	PLOCK#	132	A17	165	D4		

FIGURE 2. Terminal connections - Continued.

<b>STANDARD MICROCIRCUIT DRAWING DEFENSE SUPPLY CENTER COLUMBUS COLUMBUS, OHIO 43216-5000</b>	<b>SIZE A</b>		<b>5962-93105</b>
		<b>REVISION LEVEL C</b>	<b>SHEET 17</b>

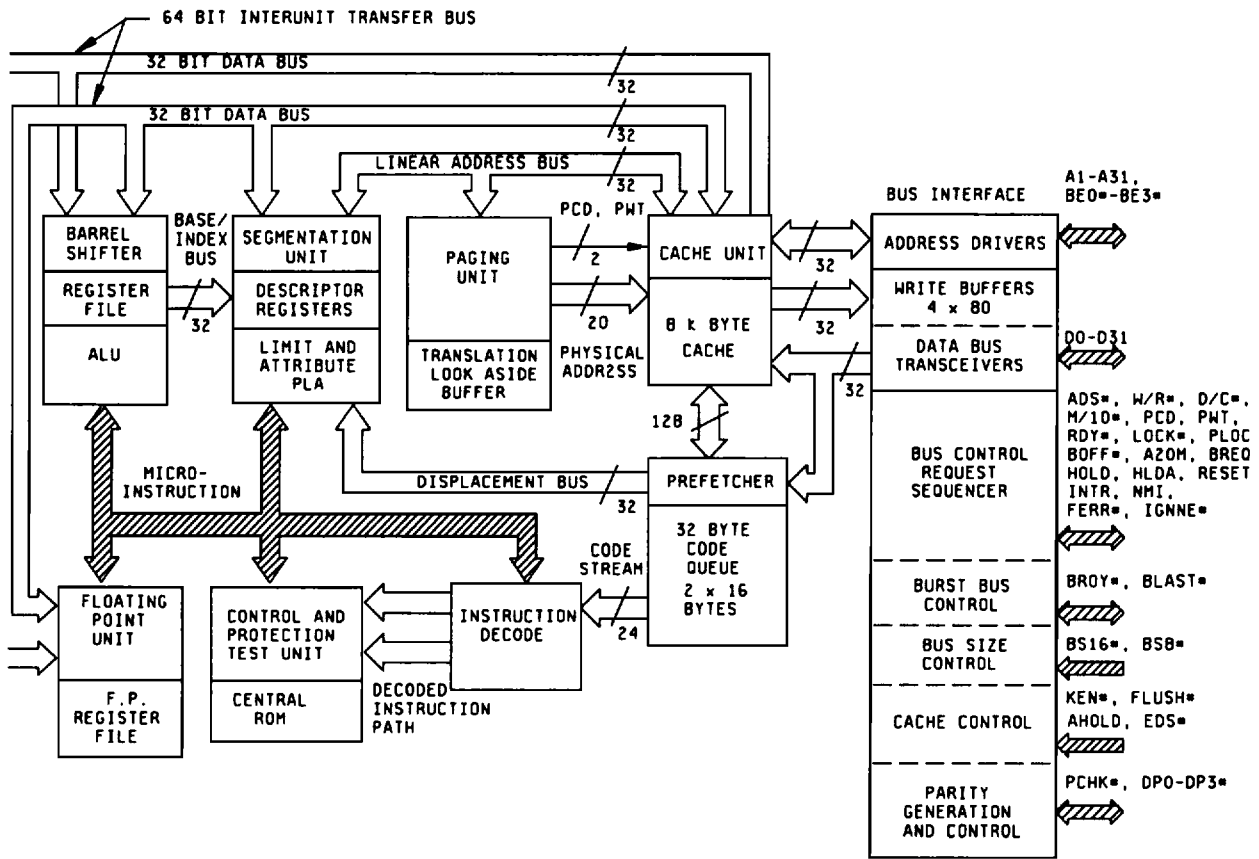

FIGURE 3. Block diagram.

STANDARD  
MICROCIRCUIT DRAWING  
DEFENSE SUPPLY CENTER COLUMBUS  
COLUMBUS, OHIO 43216-5000

SIZE  
A

5962-93105

REVISION LEVEL  
C

SHEET  
18

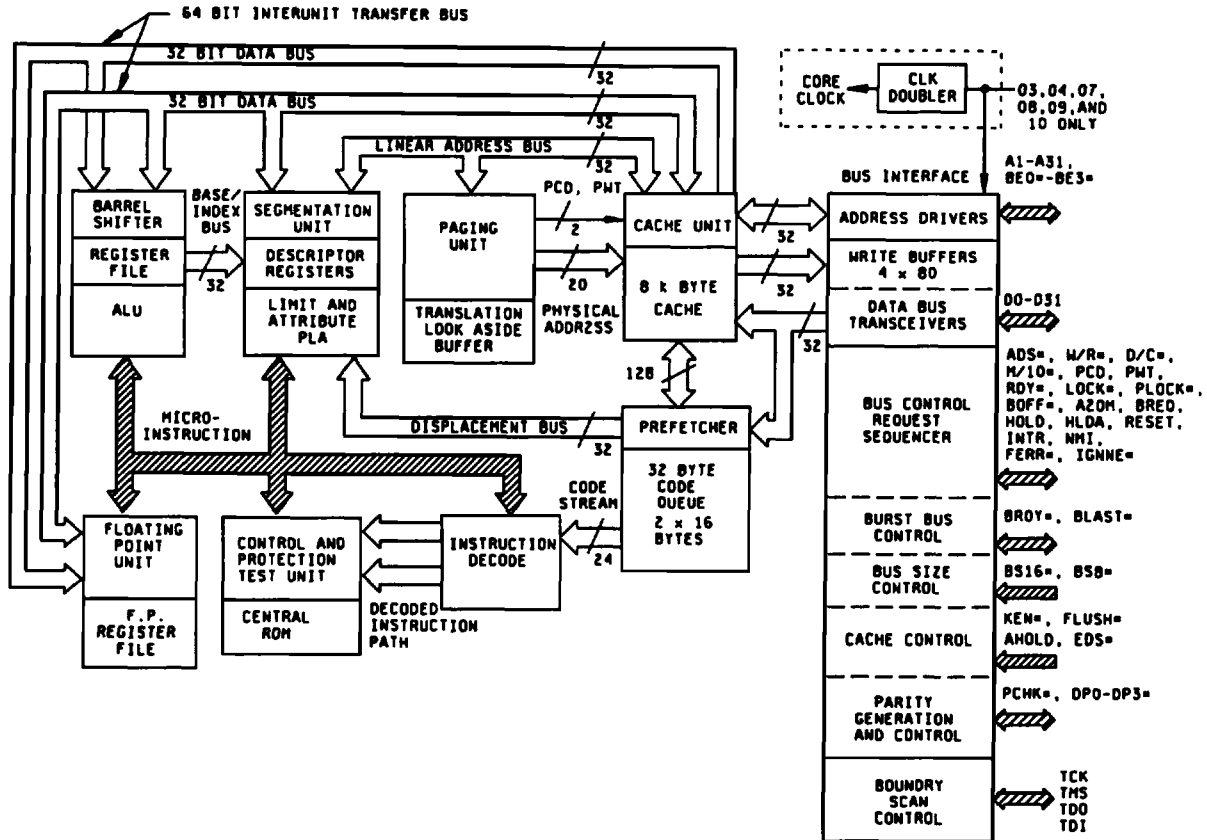

Figure 3. Block diagram. - Continued

STANDARD MICROCIRCUIT DRAWING DEFENSE SUPPLY CENTER COLUMBUS COLUMBUS, OHIO 43216-5000	SIZE <b>A</b>		5962-93105
		REVISION LEVEL C	SHEET 19

Instruction Code	Instruction Name
0000	Extest
0001	Sample
0010	Icode
0011	Private
0100	Private
0101	Private
0110	Private
0111	Private
1000	Runbist
1001	Private
1010	Private
1011	Private
1100	Private
1101	Private
1110	Private
1111	Bypass

Figure 4. Boundry scan instruction codes

<b>STANDARD MICROCIRCUIT DRAWING DEFENSE SUPPLY CENTER COLUMBUS COLUMBUS, OHIO 43216-5000</b>	<b>SIZE A</b>		<b>5962-93105</b>
		<b>REVISION LEVEL C</b>	<b>SHEET 20</b>

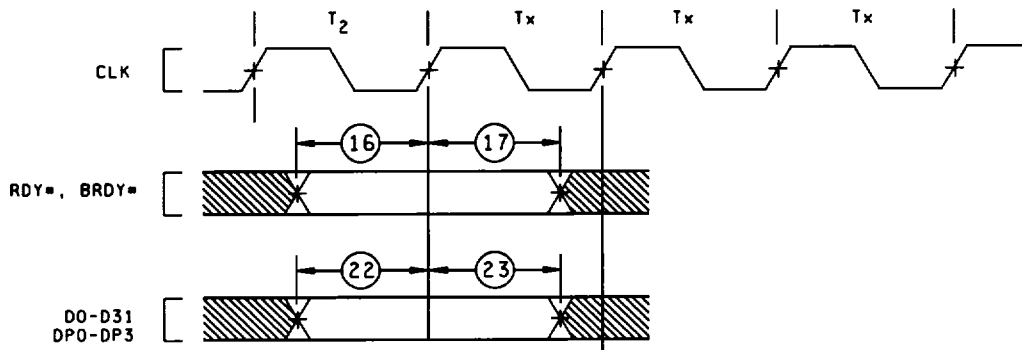
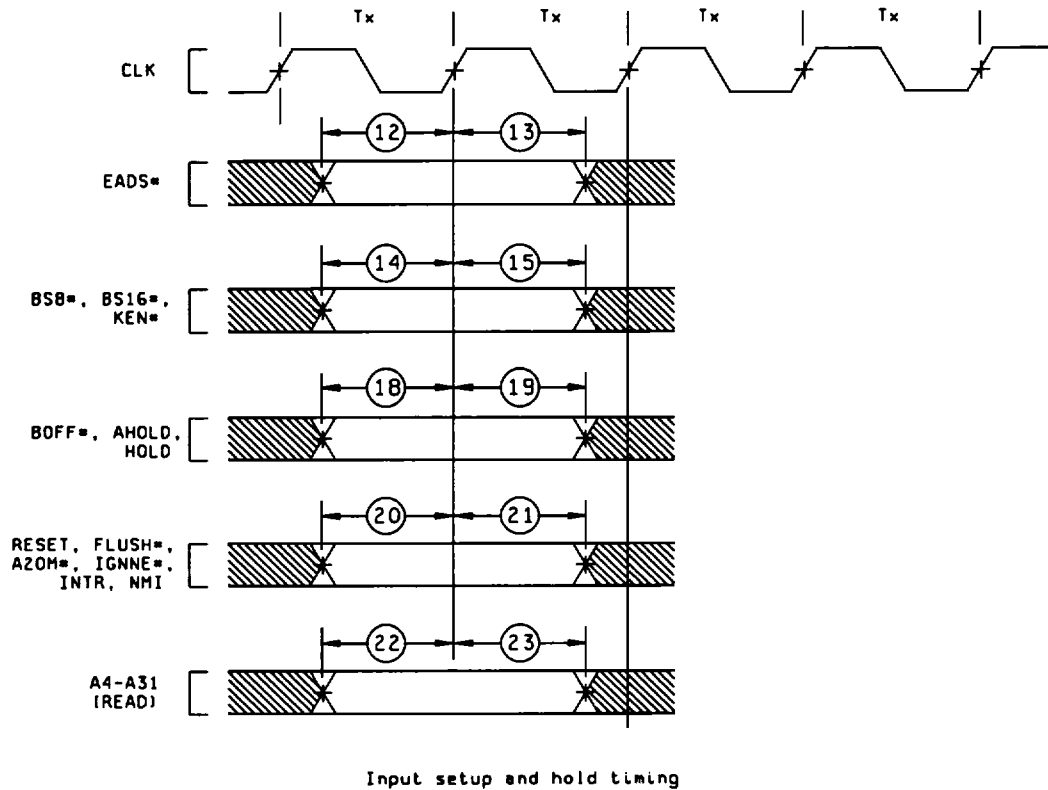
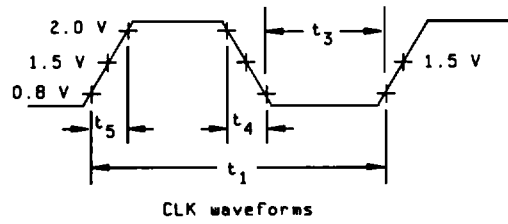

FIGURE 5. Timing waveforms.

STANDARD  
MICROCIRCUIT DRAWING  
DEFENSE SUPPLY CENTER COLUMBUS  
COLUMBUS, OHIO 43216-5000

SIZE  
A

5962-93105

REVISION LEVEL  
C

SHEET  
21

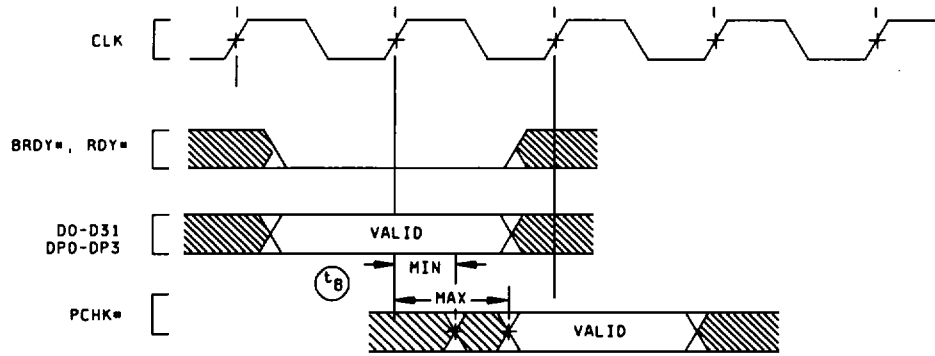

PCHK# valid delay timing

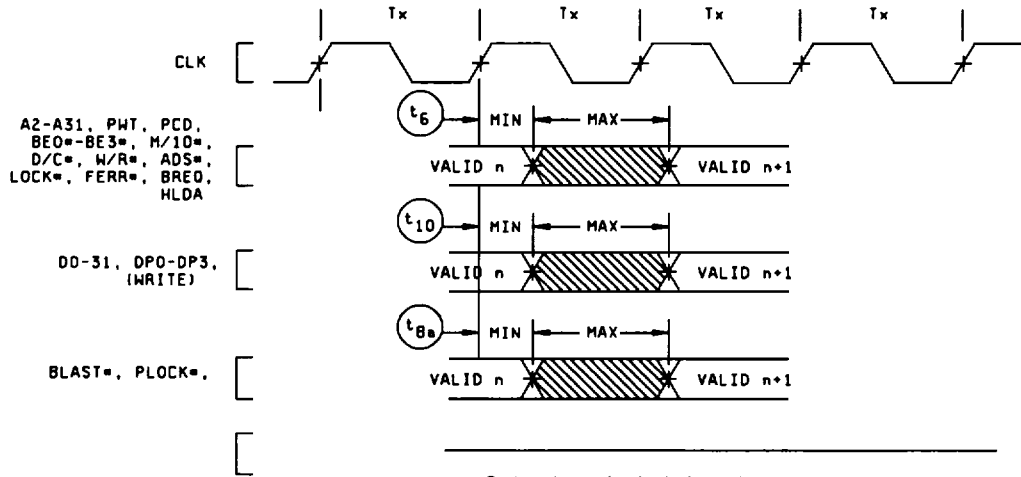

Output valid delay timing

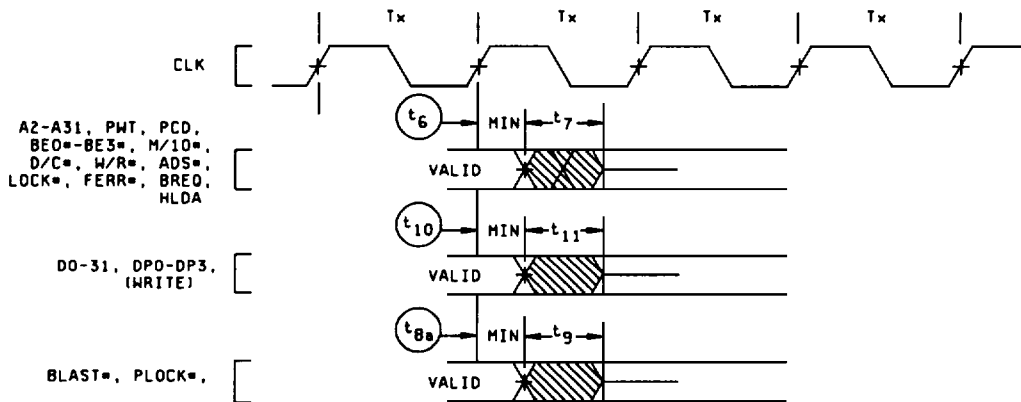

FIGURE 5. Timing waveforms - Continued.

STANDARD  
MICROCIRCUIT DRAWING  
DEFENSE SUPPLY CENTER COLUMBUS  
COLUMBUS, OHIO 43216-5000

SIZE  
A

5962-93105

REVISION LEVEL  
C

SHEET  
22

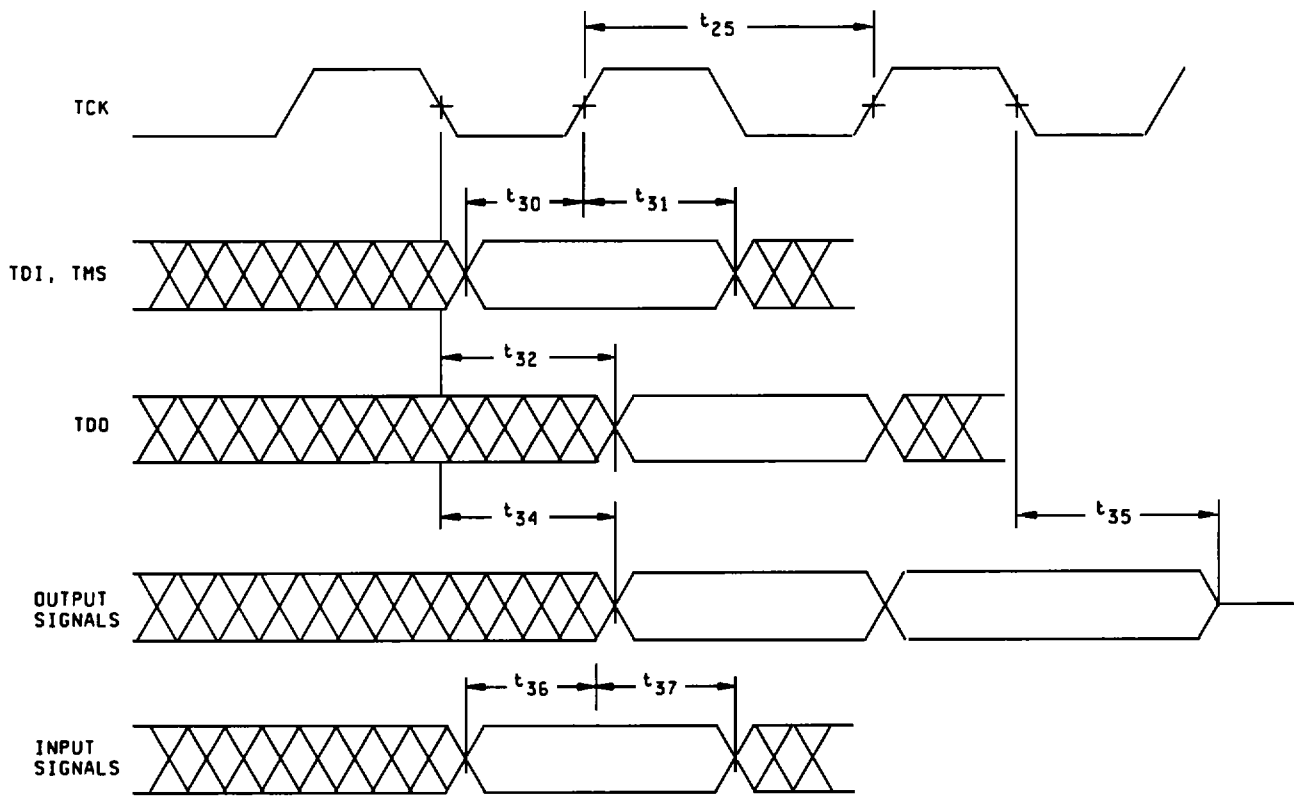

Figure 6. JTAG timing waveforms

STANDARD MICROCIRCUIT DRAWING DEFENSE SUPPLY CENTER COLUMBUS COLUMBUS, OHIO 43216-5000	SIZE <b>A</b>		5962-93105
		REVISION LEVEL C	SHEET 23

3.8 Notification of change for device class M. For device class M, notification to DSCC-VA of change of product (see 6.2 herein) involving devices acquired to this drawing is required for any change as defined in MIL-STD-973.

3.9 Verification and review for device class M. For device class M, DSCC, DSCC's agent, and the acquiring activity retain the option to review the manufacturer's facility and applicable required documentation. Offshore documentation shall be made available onshore at the option of the reviewer.

3.10 Microcircuit group assignment for device class M. Device class M devices covered by this drawing shall be in microcircuit group number 105 (see MIL-PRF-38535, appendix A).

3.11 IEEE 1149.1 compliance. Device types 03 - 10 shall be compliant with IEEE 1149.1.

4. QUALITY ASSURANCE PROVISIONS

4.1 Sampling and inspection. For device classes N, Q and V, sampling and inspection procedures shall be in accordance with MIL-PRF-38535 or as modified in the device manufacturer's Quality Management (QM) plan. The modification in the QM plan shall not affect the form, fit, or function as described herein. For device class M, sampling and inspection procedures shall be in accordance with MIL-PRF-38535, appendix A.

4.2 Screening. For device classes N, Q and V, screening shall be in accordance with MIL-PRF-38535, and shall be conducted on all devices prior to qualification and technology conformance inspection. For device class M, screening shall be in accordance with method 5004 of MIL-STD-883, and shall be conducted on all devices prior to quality conformance inspection.

4.2.1 Additional criteria for device class M.

a. Burn-in test, method 1015 of MIL-STD-883.

(1) Test condition A or D. The test circuit shall be maintained by the manufacturer under document revision level control and shall be made available to the preparing or acquiring activity upon request. The test circuit shall specify the inputs, outputs, biases, and power dissipation, as applicable, in accordance with the intent specified in test method 1015.

(2)  $T_A = +125^{\circ}\text{C}$ , minimum.

b. Interim and final electrical test parameters shall be as specified in table II herein.

4.2.2 Additional criteria for device classes N, Q and V.

a. The burn-in test duration, test condition and test temperature, or approved alternatives shall be as specified in the device manufacturer's QM plan in accordance with MIL-PRF-38535. The burn-in test circuit shall be maintained under document revision level control of the device manufacturer's Technology Review Board (TRB) in accordance with MIL-PRF-38535 and shall be made available to the acquiring or preparing activity upon request. The test circuit shall specify the inputs, outputs, biases, and power dissipation, as applicable, in accordance with the intent specified in test method 1015 of MIL-STD-883.

b. Interim and final electrical test parameters shall be as specified in table II herein.

c. Additional screening for device class V beyond the requirements of device class Q shall be as specified in MIL-PRF-38535, appendix B.

4.3 Qualification inspection for device classes N, Q and V. Qualification inspection for device classes N, Q and V shall be in accordance with MIL-PRF-38535. Inspections to be performed shall be those specified in MIL-PRF-38535 and herein for groups A, B, C, D, and E inspections (see 4.4.1 through 4.4.4).

4.4 Conformance inspection. Technology conformance inspection for classes N, Q and V shall be in accordance with MIL-PRF-38535 including groups A, B, C, D, and E inspections and as specified herein except where option 2 of MIL-PRF-38535 permits alternate in-line control testing. Quality conformance inspection for device class M shall be in accordance with MIL-PRF-38535, appendix A and as specified herein. Inspections to be performed for device class M shall be those specified in method 5005 of MIL-STD-883 and herein for groups A, B, C, D, and E inspections (see 4.4.1 through 4.4.4).

4.4.1 Group A inspection.

a. Tests shall be as specified in table II herein.

b. For device class M, subgroups 7 and 8 tests shall be sufficient to verify the functionality of the device. For device classes Q and V, subgroups 7 and 8 shall include verifying the functionality of the device; these tests shall have been fault graded in accordance with MIL-STD-883, test method 5012 (see 1.5 herein).

c. Subgroup 4 ( $C_{CLK}$ ,  $C_{IN}$  and  $C_0$ ) shall be measured only for the initial test and after process or design changes which may affect capacitance. A minimum sample size of five devices with zero rejects shall be required.

4.4.2 Group C inspection. The group C inspection end-point electrical parameters shall be as specified in table II herein.

<b>STANDARD MICROCIRCUIT DRAWING DEFENSE SUPPLY CENTER COLUMBUS COLUMBUS, OHIO 43216-5000</b>	<b>SIZE A</b>		<b>5962-93105</b>
		<b>REVISION LEVEL C</b>	<b>SHEET 24</b>



TABLE II. Electrical test requirements.

Test requirements	Subgroups (in accordance with MIL-STD-883, method 5005, table I)	Subgroups (in accordance with MIL-PRF-38535, table III)		
	Device class M	Device class N	Device class Q	Device class V
Interim electrical parameters (see 4.2)				
Final electrical parameters (see 4.2)	1, 2, 3, 7, 8, 9, 10, 11 1/	1, 2, 3, 7, 8, 9,10,11 1/	1, 2, 3, 7, 8, 9,10,11 1/	1, 2, 3, 7, 8,9,10,11 2/
Group A test requirements (see 4.4)	1, 2, 3, 4, 7, 8, 9, 10, 11	1, 2, 3, 4, 7, 8, 9, 10,11	1, 2, 3, 4, 7, 8, 9, 10,11	1, 2, 3, 4, 7, 8, 9, 10, 11
Group C end-point electrical parameters (see 4.4)	2, 8a, 10	2, 8a, 10	2, 8a, 10	2, 8a, 10
Group D end-point electrical parameters (see 4.4)	2, 8a, 10	2, 8a, 10	2, 8a, 10	2, 8a, 10
Group E end-point electrical parameters (see 4.4)				

- 1/ PDA applies to subgroup 1.
- 2/ PDA applies to subgroups 1 and 7.

4.4.2.1 Additional criteria for device class M. Steady-state life test conditions, method 1005 of MIL-STD-883:

- a. Test condition A or D. The test circuit shall be maintained by the manufacturer under document revision level control and shall be made available to the preparing or acquiring activity upon request. The test circuit shall specify the inputs, outputs, biases, and power dissipation, as applicable, in accordance with the intent specified in test method 1005 of MIL-STD-883.
- b.  $T_A = +125^\circ\text{C}$ , minimum.
- c. Test duration: 1,000 hours, except as permitted by method 1005 of MIL-STD-883.

4.4.2.2 Additional criteria for device classes N, Q and V. The steady-state life test duration, test condition and test temperature, or approved alternatives shall be as specified in the device manufacturer's QM plan in accordance with MIL-PRF-38535. The test circuit shall be maintained under document revision level control by the device manufacturer's TRB in accordance with MIL-PRF-38535 and shall be made available to the acquiring or preparing activity upon request. The test circuit shall specify the inputs, outputs, biases, and power dissipation, as applicable, in accordance with the intent specified in test method 1005 of MIL-STD-883.

4.4.3 Group D inspection. The group D inspection end-point electrical parameters shall be as specified in table II herein.

4.4.4 Group E inspection. Group E inspection is required only for parts intended to be marked as radiation hardness assured (see 3.5 herein).

- a. End-point electrical parameters shall be as specified in table II herein.
- b. For device classes N, Q and V, the devices or test vehicle shall be subjected to radiation hardness assured tests as specified in MIL-PRF-38535 for the RHA level being tested. For device class M, the devices shall be subjected to radiation hardness assured tests as specified in MIL-PRF-38535, appendix A for the RHA level being tested. All device classes must meet the postirradiation end-point electrical parameter limits as defined in table I at  $T_A = +25^\circ\text{C} \pm 5^\circ\text{C}$ , after exposure, to the subgroups specified in table II herein.
- c. When specified in the purchase order or contract, a copy of the RHA delta limits shall be supplied.

5. PACKAGING

5.1 Packaging requirements. The requirements for packaging shall be in accordance with MIL-PRF-38535 for device classes N, Q and V or MIL-PRF-38535, appendix A for device class M.

<b>STANDARD MICROCIRCUIT DRAWING DEFENSE SUPPLY CENTER COLUMBUS COLUMBUS, OHIO 43216-5000</b>	<b>SIZE A</b>		<b>5962-93105</b>
		<b>REVISION LEVEL C</b>	<b>SHEET 25</b>

6. NOTES

6.1 Intended use. Microcircuits conforming to this drawing are intended for use for Government microcircuit applications (original equipment), design applications, and logistics purposes.

6.1.1 Replaceability. Microcircuits covered by this drawing will replace the same generic device covered by a contractor-prepared specification or drawing.

6.1.2 Substitutability. Device class Q devices will replace device class M devices.

6.2 Configuration control of SMD's. All proposed changes to existing SMD's will be coordinated with the users of record for the individual documents. This coordination will be accomplished in accordance with MIL-STD-973 using DD Form 1692, Engineering Change Proposal.

6.3 Record of users. Military and industrial users should inform Defense Supply Center Columbus when a system application requires configuration control and which SMD's are applicable to that system. DSCC will maintain a record of users and this list will be used for coordination and distribution of changes to the drawings. Users of drawings covering microelectronic devices (FSC 5962) should contact DSCC-VA, telephone (614) 692-0525.

6.4 Comments. Comments on this drawing should be directed to DSCC-VA, Columbus, Ohio 43216-5000, or telephone (614) 692-0674.

6.5 Abbreviations, symbols, and definitions. The abbreviations, symbols, and definitions used herein are defined in MIL-PRF-38535 and MIL-HDBK-1331.

STANDARD MICROCIRCUIT DRAWING DEFENSE SUPPLY CENTER COLUMBUS COLUMBUS, OHIO 43216-5000	SIZE <b>A</b>		<b>5962-93105</b>
		REVISION LEVEL C	SHEET <b>26</b>

TABLE III. Pin descriptions.

Symbol	Type	Function																																				
CLK	I	Clock provides the fundamental timing and the internal operating frequency for the device. All external timing parameters are specified with respect to the rising edge of CLK.																																				
<b>ADDRESS BUS</b>																																						
A31-A4 A2-A3	I/O 0	A31-A2 are the address lines of the microprocessor. A31-A2, together with the byte enables BE0#-BE3#, define the physical area of memory or input/output space accessed. Address lines A31-A4 are used to drive addresses into the microprocessor to perform cache line invalidations. Input signals must meet setup and hold times $t_{22}$ and $t_{23}$ . A31-A2 are not driven during bus or address hold.																																				
BE0-3#	I/O	The byte enable signals indicate active bytes during read and write cycles. During the first cycle of a cache fill, the external system should assume that all byte enables are active. BE3# applies to D24-D31, BE2# applies to D16-D23, BE1# applies to D8-D15 and BE0# applied to D0-D7, BE0#-BE3# are active LOW and are not driven during bus hold.																																				
<b>DATA BUS</b>																																						
D31-D0	I/O	These are the data lines for the device. Lines D0-D7 define the least significant byte of the data bus while lines D24-D31 define the most significant byte of the data bus. These signals must meet setup and hold times $t_{22}$ and $t_{23}$ for proper operation on reads. These pins are driven during the second and subsequent clocks of write cycles.																																				
<b>DATA PARITY</b>																																						
DP0-DP3	I/O	There is one data parity pin for each byte of the data bus. Data parity is generated on all write data cycles with the same timing as the data driven by the device. Even parity information must be driven back into the microprocessor on the data parity pins with the same timing as read information to insure that the correct parity check status is indicated by the device. The signals read on these pins do not affect program execution. Input signals must meet setup and hold times $t_{22}$ and $t_{23}$ . DP0-DP3 should be connected to $V_{CC}$ through a pullup resistor in systems which do not use parity. DP0-DP3 are active HIGH and are driven during the second and subsequent clocks of write cycles.																																				
PCHK#	0	Parity status is driven on the PCHK# pin the clock after ready for read operations. The parity status is for data sampled at the end of the previous clock. A parity error is indicated by PCHK# being LOW. Parity status is only checked for enabled bytes as indicated by the byte enable and bus sized signals. PCHK# is valid only in the clock immediately after read data is returned to the microprocessor. At all other times PCHK# is inactive (HIGH). PCHK# is never floated.																																				
<b>BUS CYCLE DEFINITION</b>																																						
M/IO# D/C# W/R#	0 0 0	<p>The memory/input-output, data/control and write/read lines are the primary bus definition signals. These signals are driven valid as the ADS# signal is asserted.</p> <table border="1"> <thead> <tr> <th>M/IO#</th> <th>D/C</th> <th>W/R</th> <th>BUS CYCLE INITIATED</th> </tr> </thead> <tbody> <tr> <td>0</td> <td>0</td> <td>0</td> <td>Interrupt Acknowledge</td> </tr> <tr> <td>0</td> <td>0</td> <td>1</td> <td>Halt/Special Cycle</td> </tr> <tr> <td>0</td> <td>1</td> <td>0</td> <td>I/O Read</td> </tr> <tr> <td>0</td> <td>1</td> <td>1</td> <td>I/O Write</td> </tr> <tr> <td>1</td> <td>0</td> <td>0</td> <td>Code Read</td> </tr> <tr> <td>1</td> <td>0</td> <td>1</td> <td>Reserved</td> </tr> <tr> <td>1</td> <td>1</td> <td>0</td> <td>Memory Read</td> </tr> <tr> <td>1</td> <td>1</td> <td>1</td> <td>Memory Write</td> </tr> </tbody> </table> <p>The bus definition signals are not driven during bus hold and follow the timing of the address bus.</p>	M/IO#	D/C	W/R	BUS CYCLE INITIATED	0	0	0	Interrupt Acknowledge	0	0	1	Halt/Special Cycle	0	1	0	I/O Read	0	1	1	I/O Write	1	0	0	Code Read	1	0	1	Reserved	1	1	0	Memory Read	1	1	1	Memory Write
M/IO#	D/C	W/R	BUS CYCLE INITIATED																																			
0	0	0	Interrupt Acknowledge																																			
0	0	1	Halt/Special Cycle																																			
0	1	0	I/O Read																																			
0	1	1	I/O Write																																			
1	0	0	Code Read																																			
1	0	1	Reserved																																			
1	1	0	Memory Read																																			
1	1	1	Memory Write																																			

STANDARD  
MICROCIRCUIT DRAWING  
DEFENSE SUPPLY CENTER COLUMBUS  
COLUMBUS, OHIO 43216-5000

SIZE  
A

5962-93105

REVISION LEVEL  
C

SHEET  
27

TABLE III. Pin descriptions - Continued.

Symbol	Type	Function
LOCK#	0	The bus lock pin indicates that the current bus cycle is locked. The device will not allow a bus hold when LOCK# is asserted (but address holds are allowed). LOCK# goes active in the first clock of the first locked bus cycle and goes inactive after the last clock of the last locked bus cycle. The last locked cycle ends when ready is returned. LOCK# is active LOW and is not driven during bus hold. Locked read cycles will not be transformed into cache fill cycles if KEN# is returned active.
PLOCK#	0	The Pseudo-lock pin indicates that the current bus transaction requires more than one bus cycle to complete. Examples of such operations are floating point long reads and writes (64 bits), segment table descriptor reads (64 bits), segment table descriptor reads (64 bits), in addition to cache line fills (128 bits). The device will drive PLOCK# active until the addresses for the last bus cycle of the transaction have been driven regardless of whether RDY# or BRDY# have been returned. Normally PLOCK# and BLAST# are inverse of each other. However, during the first bus cycle of a 64-bit floating point write, both PLOCK# and BLAST# will be asserted PLOCK# is a function of the BSB#, BS16#, and KEN# inputs. PLOCK# should be sampled only in the clock ready is returned. PLOCK# is active LOW and is not driven during bus hold.
<b>BUS CONTROL</b>		
ADS#	0	The address status output indicates that a valid bus cycle definition and address are available on the cycle definition lines and address bus. ADS# is driven active in the same clock as addresses are driven. ADS# is active LOW and is not driven during bus hold.
RDY#	1	The non-burst ready input indicates that the current bus cycle is complete. RDY# indicates that the external system has presented valid data on the data pins in response to a read or that the external system has accepted data from the device in response to a write, RDY# is ignored when the bus is idle and at the end of the first clock of the bus cycle. RDY# is active LOW, and is not provided with an internal pullup resistor. RDY# must satisfy setup and hold times $t_{16}$ and $t_{17}$ for proper chip operation. RDY# is active during address hold. Data can be returned to the processor while AHOLD is active.
<b>BURST CONTROL</b>		
BRDY#	1	The burst ready input performs the same function during a burst cycle that RDY# performs during a non-burst cycle. BRDY# is ignored when the bus is idle at the end of the first clock in a bus cycle. BRDY# is sampled in the second and subsequent clocks of a burst cycle. The data presented on the data bus will be strobed into the microprocessor when BRDY# is sampled active. If RDY# is returned simultaneously with BRDY#, BRDY# is ignored and the burst cycle is prematurely aborted. BRDY# is active LOW and is provided with a small pullup resistor. BRDY# must satisfy the setup and hold times $t_{16}$ and $t_{17}$ .
BLAST#	0	The burst last signal indicates that the next time BRDY# is returned the burst bus cycle is complete. BLAST# is active for both burst and non-burst bus cycles. BLAST# is active LOW and is not driven during bus hold.
<b>INTERRUPTS</b>		
RESET	1	The reset input forces the device to begin execution at a known state. The microprocessor cannot begin execution of instructions until at least 1ms after $V_{CC}$ and CLK have reached their proper DC and AC specifications. The RESET pin should remain active during this time to insure proper microprocessor operation. RESET is active HIGH. RESET is asynchronous but must meet setup and hold times $t_{20}$ and $t_{21}$ for recognition in any specific clock.

STANDARD  
MICROCIRCUIT DRAWING  
DEFENSE SUPPLY CENTER COLUMBUS  
COLUMBUS, OHIO 43216-5000

SIZE  
A

5962-93105

REVISION LEVEL  
C

SHEET  
28

TABLE III. Pin descriptions - Continued.

Symbol	Type	Function
INTR	I	The maskable interrupt indicates that an external interrupt has been generated. If the internal interrupt flag is set in EFLAGS, active interrupt processing will be initiated. The device will generate two locked interrupt acknowledge bus cycles in response to the INTR pin going active. INTR must remain active until the interrupt acknowledges have been performed to assure that the interrupt is recognized. INTR is active HIGH and is not provided with an internal pulldown resistor. INTR is asynchronous, but must meet setup and hold times $t_{20}$ and $t_{21}$ for recognition in any specific clock.
NMI	I	The non-maskable interrupt request signal indicates that an external non-maskable interrupt has been generated. NMI is rising edge sensitive. NMI must be held LOW for at least four CLK periods before this rising edge. NMI is not provide with an internal pulldown resistor. NMI is asynchronous, but must meet setup and hold times $t_{20}$ and $t_{21}$ for recognition in any specific clock.
<b>BUS ARBITRATION</b>		
BREQ	O	The internal cycle pending signal indicates that the device has internally generated a bus request. BREQ is generated whether or not the device is driving the bus. BREQ is active HIGH and is never floated.
HOLD	I	The bus hold request allows another bus master complete control of the device bus. In response to HOLD going active the device will float most of its output and input/output pins. HLDA will be asserted after completing the current bus cycle, burst cycle or sequence of locked cycles. The device will remain in this state until HOLD is deasserted. HOLD is active high and is not provided with an internal pulldown resistor. HOLD must satisfy setup and hold times $t_{18}$ and $t_{19}$ for proper operation.
HLDA	O	Hold acknowledge goes active in response to a hold request presented on the HOLD pin. HLDA indicates that the device has given the bus to another local bus master. HLDA is driven active in the same clock that the device floats its bus. HLDA is driven inactive when leaving bus hold. HLDA is active HIGH and remains driven during bus hold.
BOFF#	I	The backoff input forces the device to float its bus in the next clock. The microprocessor will float all pins normally floated during bus hold but HLDA will not be asserted in response to BOFF#. BOFF# has higher priority than RDY# or BRDY#; if both are returned in the same clock, BOFF# takes effect. The microprocessor remains in bus hold until BOFF# is negated. If a bus cycle was in progress when BOFF# was asserted the cycle will be restarted. BOFF# is active LOW and must meet setup and hold times $t_{18}$ and $t_{19}$ for proper operation.
<b>CACHE INVALIDATION</b>		
AHOLD	I	The address hold request allows another bus master access to the device address bus for a cache invalidation cycle. The device will stop driving its address bus in the clock following AHOLD going active. Only the address bus will be floated during address hold, the remainder of the bus will remain active. AHOLD is active HIGH and is provided with a small internal pulldown resistor. For proper operation AHOLD must meet setup and hold times $t_{18}$ and $t_{19}$ .
EADS#	I	This signal indicates that a valid external address has been driven onto the device microprocessor address pins. This address will be used to perform an internal cache invalidation cycle. EADS# is active LOW and is provided with an internal pullup resistor. EADS# must satisfy setup and hold times $t_{12}$ and $t_{13}$ for proper operation.

<b>STANDARD MICROCIRCUIT DRAWING DEFENSE SUPPLY CENTER COLUMBUS COLUMBUS, OHIO 43216-5000</b>	<b>SIZE A</b>		<b>5962-93105</b>
		<b>REVISION LEVEL C</b>	<b>SHEET 29</b>

TABLE III. Pin descriptions - Continued.

Symbol	Type	Function
<b>CACHE CONTROL</b>		
KEN#	I	The cache enable pin is used to determine whether the current cycle is cacheable. When the device generates a cycle that can be cached and KEN# is active, the cycle will become a cache line fill cycle. Returning KEN# active one clock before ready during the last read in the cache line fill will cause the line to be placed in the on-chip cache. KEN# is active LOW and is provided with a small internal pullup resistor. KEN# must satisfy setup and hold times $t_{14}$ and $t_{15}$ for operation.
FLUSH#	I	The cache flush input forces the device to flush its entire internal cache. FLUSH# is active low and need only be asserted for one clock. FLUSH# is asynchronous but setup and hold times $t_{20}$ and $t_{21}$ must be met before the falling edge of RESET caused the device to enter the tri-state test mode.
<b>PAGE CACHEABILITY</b>		
PWT PCD	0 0	The page write-through and page cached disable pins reflect the state of the page attribute bits. PWT and PCD, in the page table entry or page directory entry. If paging is disabled or for cycles that are not paged, PWT and PCD reflect the state of the PWT and PCD bits in control register 3. PWT and PCD have the same timing as the cycle definition pins(M/IO#, D/C# and W/R#). PWT and PCD are active HIGH and are not driven during bus hold. PCD is masked by the cache disable bit (CD) in Control Register 0.
<b>NUMERIC ERROR REPORTING</b>		
FERR#	0	The floating point error pin is driven active when a floating point error occurs. FERR# is included for compatibility with systems using DOS type floating point error reporting. FERR# will not go active if FP errors are masked in FPU register. FERR# is active LOW, and is not floated during bus hold.
IGNNE#	I	When the ignore numeric error pin is asserted the device will ignore a numeric error and continue executing non-control floating point instructions, but FERR# will still be activated by the device. When IGNNE# is deasserted the device will freeze on a non-control floating point instruction, if a previous floating point instruction caused an error. IGNNE# has no effect when the NE bit in control register 0 is set. IGNNE# is active LOW and is provided with a small internal pullup resistor. IGNNE# is asynchronous but setup and hold times $t_{20}$ and $t_{21}$ must be met to insure recognition on any specific clock.
<b>BUS SIZE CONTROL</b>		
BS16# BS8#	I I	The bus size 16 and bus size 8 pins (bus sizing pins) cause the device to run multiple bus cycles to complete a request from devices that cannot provide or accept 32 bits of data in a single cycle. The bus sizing pins are sampled every clock. The state of these pins in the clock before ready is used by the device to determine the bus size. These signals are active LOW and are provided with internal pullup resistors. These inputs must satisfy setup and hold times $t_{14}$ and $t_{15}$ for proper operation.
A20M#	I	When the address bit 20 mask pin is asserted the military 486 processor mask physical address bit 20 (A20) before performing a lookup to the internal cache or driving a memory cycle on the bus. A20M# emulates the address wraparound at one Mbyte, which occurs on the 8086 processor. A20M# is active LOW and should be asserted only when the processor is in real mode. This pin is asynchronous but should be setup and hold times $t_{20}$ and $t_{21}$ for recognition in any specific clock. For proper operation, A20M# should be sampled high at the falling edge of RESET.

<b>STANDARD MICROCIRCUIT DRAWING DEFENSE SUPPLY CENTER COLUMBUS COLUMBUS, OHIO 43216-5000</b>	<b>SIZE A</b>		<b>5962-93105</b>
		<b>REVISION LEVEL C</b>	<b>SHEET 30</b>

Symbol	Type	Function
TCK	I	Test clock is an input to the device and provides the clocking function required by the JTAG boundary scan feature. TCK is used to clock state information and data into and out of the component. State select information and data are clocked into the component on the rising edge of TCK and TMS and TDI, respectively. Data is clocked out of the part on the falling edge of TCK on TDO.
TDI	I	Test data input is the serial input used to shift JTAG instructions and data within the component. TDI is sampled on the rising edge of TCK, during the SHIFT-IR and the SHIFT-DR TAP controller states. During all other tap controller states, TDI is a "don't care",
TDO	O	Test data output is the serial input used to shift JTAG instructions and data out of the component. TDO is driven on the falling edge of TCK during the SHIFT-IR and SHIFT-DR TAP controller states. At all other times TDO is driven to the high impedance state.
TMS	I	Test mode select is decoded by the JTAG TAP (Test access Port) to select the operation of the test logic. TMS is sampled on the rising edge of TCK. To guarantee deterministic behavior of the TAP controller TMS is provided with an internal pull-up resistor.
SRESET	I	The soft reset pin duplicates all the functionality of the RESET pin with the following exception: The SMBASE registers will retain its previous value. For soft resets, SSRESET should remain active for at least 15 CLK periods. Sreset is active HIGH, SRESET is asynchronous but must meet setup and hold times $t_{20}$ and $t_{21}$ for recognition in any specific clock.
SMI#	I	The system management interrupt input is used to invoke the system management mode (SMM). SMI# is a falling edge triggered signal which forces the processor into SMM at the completion of the current instruction. SMI# is recognized on an instruction boundary and at each iteration for repeat string instructions. SMI# does not break LOCKed bys cycles and cannot interrupt a currently executing SMM. The processor will latch the falling edge of one pending SMI# signal while the processor is executing an existing SMI#. The nested SMI# will not be recognized until after the execution of a Resume(RSM) instruction.
SMIACT#	O	The System Management Interrupt ACTIVE is an active low output, indicating that the processor is operating in SMM. It is asserted when the processor begins to execute the SMI# state save sequence and will remain active LOW until the processor executes the last state restore cycle out of SMRAM.
STPCLK#	I	The Stop Clock request input signal indicates a request has been made to turn off the CLK input. When the processor recognizes a STPCLK#, the processor will stop execution on the next instruction boundary, unless superseded by a higher priority interrupt, empty all internal pipelines and the write buffers and generate a Stop Grant acknowledge bus cycle, STPCLK# is active LOW and is provided with an internal pull-up resistor. STPCLK# is an asynchronous signal, but must remain active until the processor issues the Stop Grant bus cycle. STPCLK# may be de0asserted at any time after the processor has issued the Stop Grant bus cycle.

6.6 Sources of supply.

6.6.1 Sources of supply for device classes N, Q and V. Sources of supply for device classes Q and V are listed in QML-38535. The vendors listed in QML-38535 have submitted a certificate of compliance (see 3.6 herein) to DSCC-VA and have agreed to this drawing.

6.6.2 Approved sources of supply for device class M. Approved sources of supply for class M are listed in MIL-HDBK-103. The vendors listed in MIL-HDBK-103 have agreed to this drawing and a certificate of compliance (see 3.6 herein) has been submitted to and accepted by DSCC-VA.

<b>STANDARD MICROCIRCUIT DRAWING DEFENSE SUPPLY CENTER COLUMBUS COLUMBUS, OHIO 43216-5000</b>	<b>SIZE A</b>		<b>5962-93105</b>
		<b>REVISION LEVEL C</b>	<b>SHEET 31</b>

## STANDARD MICROCIRCUIT DRAWING SOURCE APPROVAL BULLETIN

DATE: 96-10-28

Approved sources of supply for SMD 5962-93105 are listed below for immediate acquisition only and shall be added to MIL-HDBK-103 during the next revision. MIL-HDBK-103 will be revised to include the addition or deletion of sources. The vendors listed below have agreed to this drawing and a certificate of compliance has been submitted to and accepted by DSCC-VA. This bulletin is superseded by the next dated revision of MIL-HDBK-103.

Standard microcircuit drawing PIN 1/	Vendor CAGE number	Vendor similar PIN 2/
5962-9310501MXA	3/	MG80486DX25
5962-9310501MYA	34649	MQ80486DX25
5962-9310502MXA	3/	MG80486DX33
5962-9310502MYA	34649	MQ80486DX33
5962-9310503QXA	3/	MG80486DX250
5962-9310503QYA	3/	MQ80486DX250
5962-9310504QXA	3/	MG80486DX266
5962-9310504QYA	3/	MQ80486DX266
5962-9310505QXA	34649	MG80486DX25
5962-9310506QXA	34649	MG80486DX33
5962-9310507QXA	34649	MG80486DX250
5962-9310507QYA	34649	MQ80486DX250
5962-9310508QXA	34649	MG80486DX266
5962-9310508QYA	34649	MQ80486DX266
5962-9310509NXA	34649	TA80486DX250
5962-9310509NYA	34649	TQ80486DX250
5962-9310510NXA	34649	TA80486DX266
5962-9310510NYA	34649	TQ80486DX266

- 1/ The lead finish shown for each PIN representing a hermetic package is the most readily available from the manufacturer listed for that part. The device manufacturers listed herein are authorized to supply alternate lead finishes "A", "B", or "C" at their discretion. Contact the listed approved source of supply for further information.
- 2/ **Caution.** Do not use this number for item acquisition. Items acquired to this number may not satisfy the performance requirements of this drawing.
- 3/ No source of supply.

Vendor CAGE  
number

34649

Vendor name  
and address

Intel Corporation  
3065 Bowers Avenue  
Santa Clara, CA 95052-8126  
Point of Contact: 5000 W. Chandler Boulevard  
Chandler, AZ 85226

The information contained herein is disseminated for convenience only and the Government assumes no liability whatsoever for any inaccuracies in the information bulletin.