

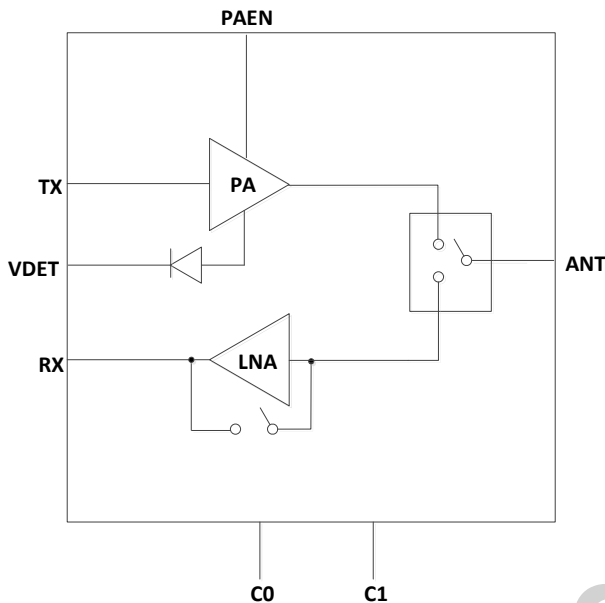

5GHz WLAN 802.11ax Front-End Module



Description

KCT8539SD-1 is a highly integrated RF Front-End Integrated Circuit incorporates key RF functionality needed for IEEE 802.11a/n/ac/ax WLAN systems operating in the 5.15-5.85GHz range. KCT8539SD-1 integrates a high-efficiency high-linearity power amplifier (PA), a low noise amplifier (LNA) with bypass, the associated matching network, LO rejection and harmonic filters all in one device.

KCT8539SD-1 has simple and low-voltage control logic, and requires minimal external components. A power detector is also integrated for accurately monitoring of output power from the PA.

KCT8539SD-1 is assembled in a compact, low-profile 3x3x0.75mm 16-lead QFN package. KCT8539SD-1 is the ideal RF front-end solution for implementing 5GHz high-power WLAN systems supporting multiple standards including 802.11a/n/ac/ax.

Applications

- ▶ 802.11ax networking and personal computing systems
- ▶ PC cards, PCMCIA cards, Mini-cards, and half mini-cards
- ▶ WLAN-enable wireless video systems

FEATURES

- ▶ Integrated 802.11ax 5GHz PA, LNA with bypass and T/R switch
- ▶ Fully-matched input and output
- ▶ Nominal operating voltage at 5V
- ▶ Integrated power detector
- ▶ Transmit gain: 30.5dB at 5V
- ▶ Receive gain: 13.5dB at 5V
- ▶ Noise figure: 3.2dB at 5V
- ▶ Output power: +21.5dBm @ -40dB DEVM, HE160/MCS11, 5V
+23dBm @ -35dB DEVM, VHT80/MCS9, 5V
+24dBm @ -30dB DEVM, HT20/MCS7, 5V
- ▶ ESD protection circuitry on all PINs
- ▶ Minimal external components required
- ▶ Small package: QFN-16L 3mm x 3mm x 0.75mm (MSL3, 260 °C per JEDEC J-STD-020)
- ▶ ROHS and REACH Compliant



PIN ASSIGNMENTS

Pin Number	Pin Name	Description
1	C1	Switch Control logic 1
2	C0	Switch Control logic 0
3,6,7,13,15,16,17	GND	Ground – Must be connected to ground in the application circuit
4	VDD	LNA supply voltage
5	RX	RF output port from LNA or Bypass – DC shorted to ground
8	TX	RF input port from the Transceiver – DC shorted to ground
9	PAEN	PA enable
10,11	VCC	PA supply voltage
12	VDET	Detector output voltage
14	ANT	Antenna port – RF signal from the PA or RF signal applied to the LNA – DC shorted to ground

PIN-OUT DIAGRAM (Top View)

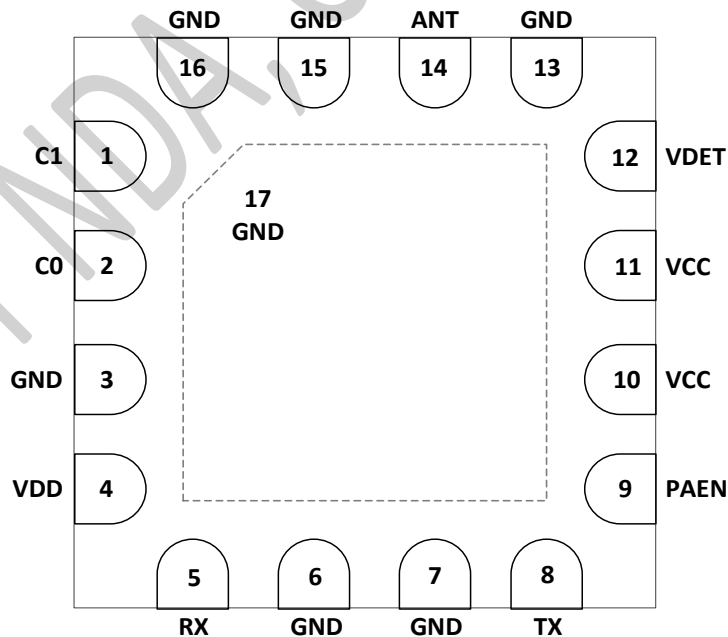



ABSOLUTE MAXIMUM RATINGS

Parameters	Units	Min	Max	Conditions
DC Supply Voltage	V	-1	+6.0	VDD and VCC Pins
DC Input on Control pins	V	-1	+3.6	All Control Pins
Maximum TX Input Power (50-ohm load, No Damage)	dBm		+18	
LNA On Maximum RX Input Power (No Damage)	dBm		+18	
Bypass Mode Maximum RX Input Power (No Damage)	dBm		+21	
Storage Temperature	°C	-40	+150	
Junction Temperature	°C		TBD	
Thermal Resistance (θ_{JC})	°C/W		+35	

NOTE: Sustained operation at or above the Absolute Maximum Ratings for any one or combinations of the above parameters may result in permanent damage to the device and is not recommended.

All Maximum RF Input Power Ratings assume 50-ohm terminal impedance.

NOMINAL OPERATING CONDITIONS

Parameters	Units	Min	Typical	Max	Conditions
DC Supply Voltage	V	4.75	5	5.25	VDD and VCC Pins
Control Pin Voltage- Logic High	V	1.6		3.6	
Control Pin Voltage- Logic Low	V	0		0.4	
Control Pin DC Current C0 C1	μA		150 150		@1.6V
Operating Temperature	°C	-40	+25	+85	

KCT8539SD-1 ELECTRICAL SPECIFICATIONS

(VDD=VCC=5V, T=25°C, All Unused Ports Terminated with 50Ω, Unless Otherwise Noted)

Parameters	Units	Min	Typ	Max	Conditions
Frequency Range	GHz	5.15		5.85	
Transmit Mode					
Small Signal Gain	dB	28.5	30.5	33	CW Signal; Input Power=-25dBm
Gain Flatness	dB		±0.5		Across any 160MHz bandwidth
Output Power	dBm	19.5 22 23 26	21.5 23 24 27		With -50dB EVM source, AT off: DEVM=-40dB, HE160/MCS11/200μs, Preamble only DEVM=-35dB, VHT80/MCS9/200μs, Preamble only DEVM=-30dB, HT20/MCS7/200μs, Preamble only HT20/MCS0, Mask Compliance



Parameters	Units	Min	Typ	Max	Conditions
Current Consumption	mA	210 285 305 310 410	240 325 355 375 480	265 365 405 440 550	Modulated Signal, 100% duty cycle @ No RF @+21.5dBm @+23dBm @+24dBm @+27dBm
Harmonic 2nd Harmonics 3rd Harmonics	dBm/MHz		-30 -45	-25 -40	Pout=+27dBm, HT20/MCS0 Signal
Input Return Loss	dB		8		
Output Return Loss	dB		15		
Output Power of P1dB	dBm	28.5	30		
Power Detector Output	V	0.05 0.25 0.73 0.83 0.94	0.10 0.32 0.80 0.90 1.02	0.15 0.39 0.87 0.97 1.10	100% duty modulated signal @ No RF @+10dBm @+21.5dBm @+24dBm @+27dBm
Isolation	dB	38	44		From ANT to RX Pin
PA Switching Time	ns		380		From 50% logic level change to 90%/10% power level TX <-> SD
Receive Mode – LNA On					
Gain	dB	11.5	13.5	15.5	
Noise Figure	dB		3.2		
Input Power of P1dB	dBm	-7	-5		
Input Return Loss	dB		7		
Output Return Loss	dB		10		
Isolation	dB	15 25	20 31		From ANT to TX Pin From RX to TX Pin
Switching Time	ns		400 400		From 50% logic level change to 90%/10% power level LNA <-> TX LNA <-> Bypass
LNA current	mA		17		
Receive Bypass Mode					
Insertion Loss	dB	2.5	4.5	6.5	
Input Power of P1dB	dBm	19	21		
Input Return Loss	dB		8		
Output Return Loss	dB		11		
Isolation	dB	32 28	37 33		From ANT to TX Pin From RX to TX Pin
Bypass Current	mA		0.5	1.5	



CONTROL LOGIC TABLE

PA_EN	C1	C0	Mode of Operation
1	1	0	Transmit Mode
0	0	1	Receive LNA Mode
0	1	1	Bypass Mode
0	0	0	Shutdown Mode

Note: "1" denotes high voltage state at Control Pins
"0" denotes low voltage state at Control Pins

PRODUCT QUALIFICATION

Parameters	Units	Min	Max	Conditions
ESD – Human Body Mode	V	1500		HBM
ESD – Charge Device Mode	V	2000		CDM

ESD HANDLING: Although this device is designed to be as robust as possible, electrostatic discharge (ESD) can damage this device. This device must be protected at all times from ESD when handling or transporting. Static charges may easily produce potentials of several kilovolts on the human body or equipment, which can discharge without detection.

Industry-standard ESD handling precautions should be used at all times.

ORDERING INFORMATION

Product Description	Product Part Number	Package Type	Package Quantity
KCT8539SD-1: 5GHz WLAN Front-End Module	KCT8539SD-1	13" tape and reel	5000pcs / reel



APPLICATION SCHEMATIC

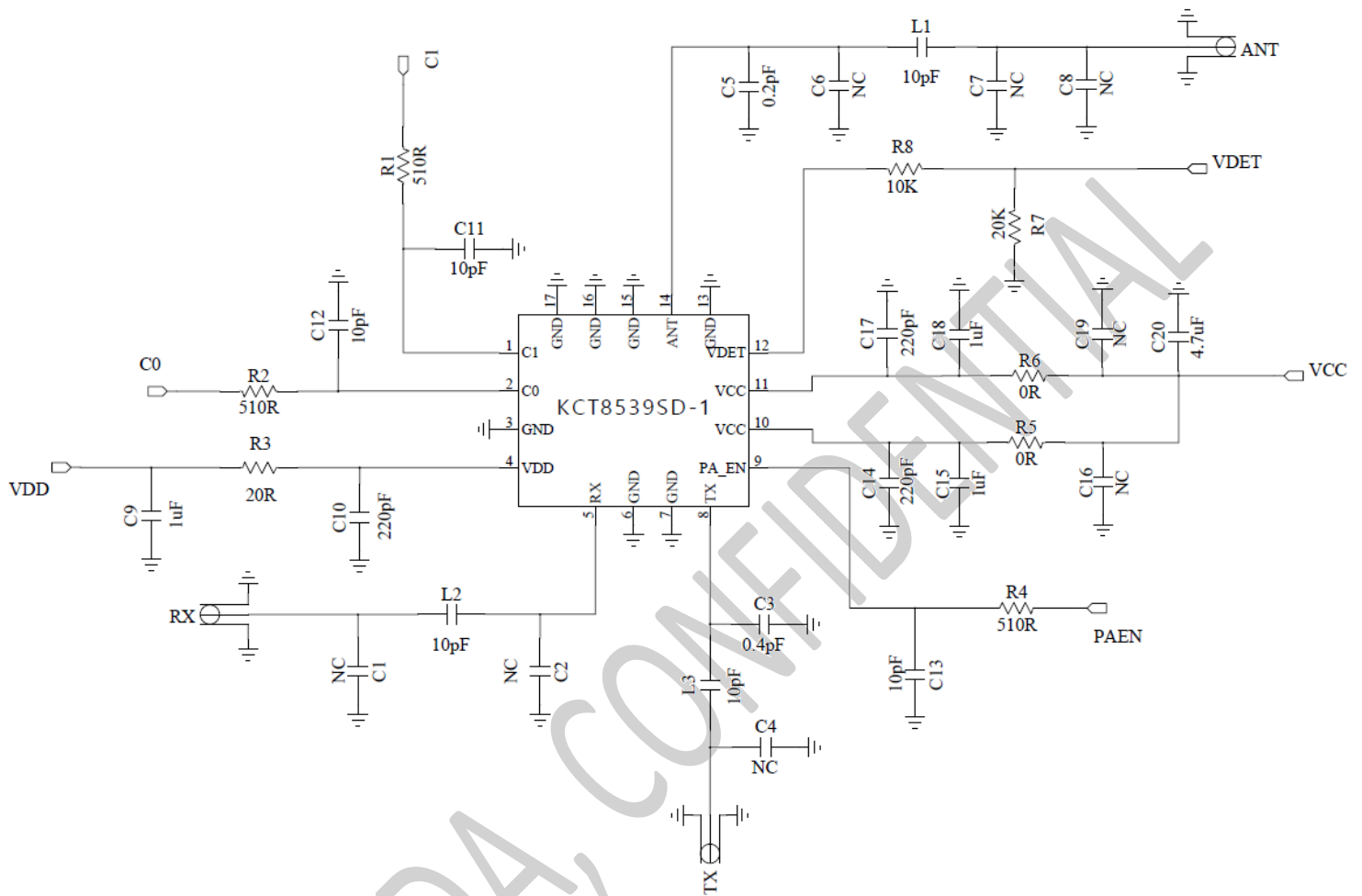

KCT NDA, CONFIDENTIAL



EVB PICTURE and EVB BOM

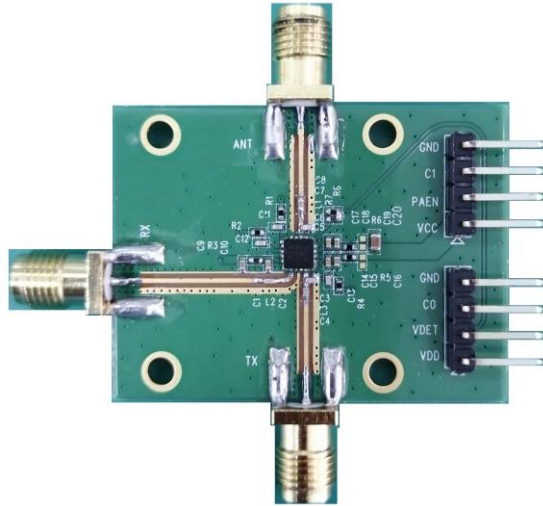

[EVB Assembly]

Reference	Value	Footprint	Notes
C3	0.4PF	0402	Murata C0G series
C5	0.2PF	0402	Murata C0G series
L1,L2,L3,C11,C12,C13	10PF	0402	Murata C0G series
C10,C14,C17	220PF	0402	Murata X5R/X7R series
C9,C15,C18	1 μ F	0402	Murata X5R/X7R series
C20	4.7 μ F	0603	Murata X5R/X7R series
R3	20ohm	0402	Yageo RC0402 series
R5,R6	0ohm	0402	Yageo RC0402 series
R7	20Kohm	0402	Yageo RC0402 series
R8	10Kohm	0402	Yageo RC0402 series
R1,R2,R4	510ohm	0402	Yageo RC0402 series Control pin protect resistor

[EVB BOM]



PCB LAYOUT FOOTPRINT (All dimensions are in millimeters)

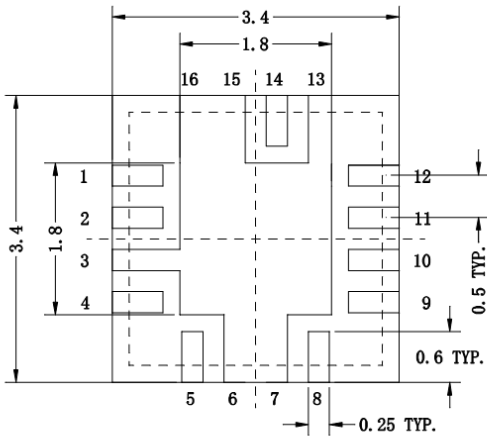

Board Metal

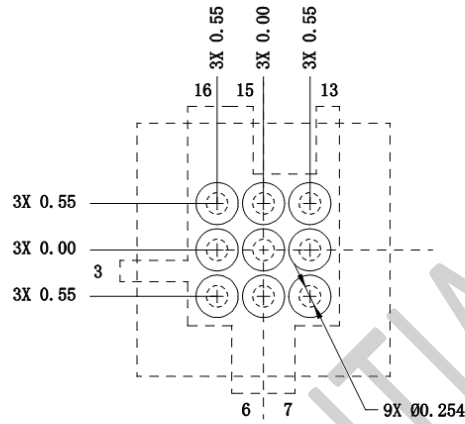

Via Pattern

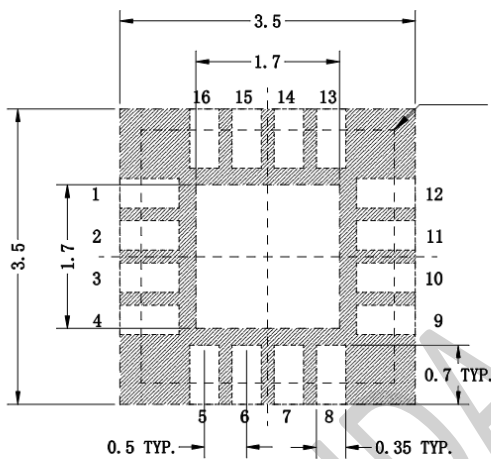

Solder Mask Pattern

Package outline

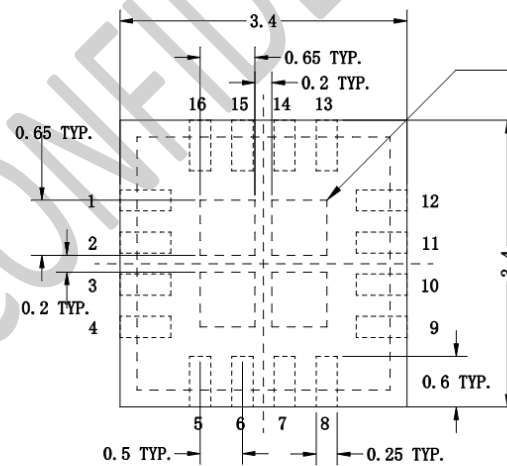

Stencil Pattern

58% Solder Coverage on Center Pad



PACKAGE DIMENSIONS (All Dimensions in mm)

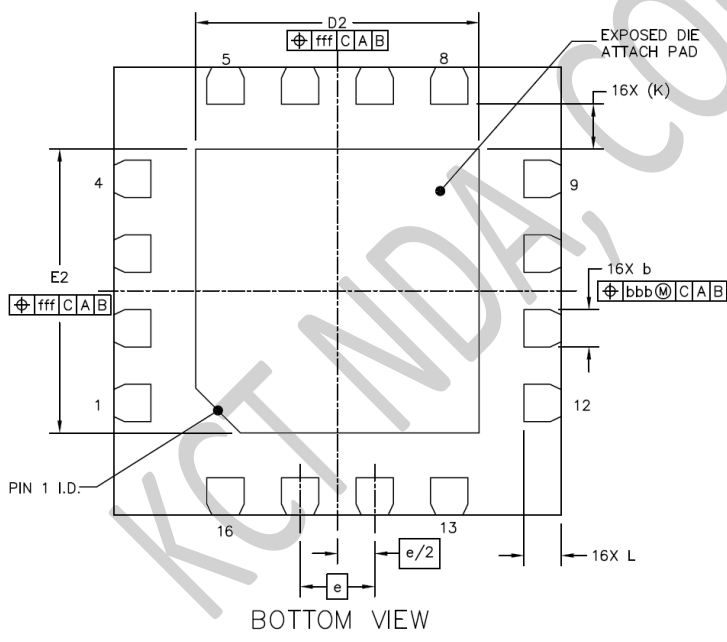
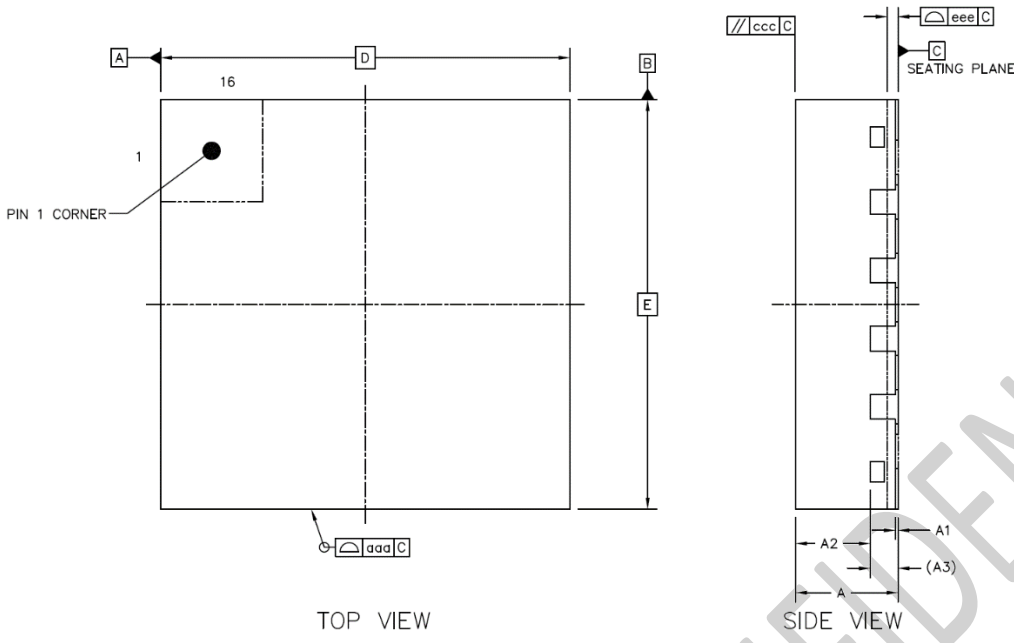

	SYMBOL	MIN	NOM	MAX	
TOTAL THICKNESS	A	0.7	0.75	0.8	
STAND OFF	A1	0	0.02	0.05	
MOLD THICKNESS	A2	---	0.55	---	
L/F THICKNESS	A3	0.203 REF			
LEAD WIDTH	b	0.2	0.25	0.3	
BODY SIZE	X	3 BSC			
	Y	3 BSC			
LEAD PITCH	e	0.5 BSC			
EP SIZE	X	D2	1.8	1.9	2
	Y	E2	1.8	1.9	2
LEAD LENGTH	L	0.15	0.25	0.35	
LEAD TIP TO EXPOSED PAD EDGE	K	0.3 REF			
PACKAGE EDGE TOLERANCE	aaa	0.1			
MOLD FLATNESS	ccc	0.1			
COPLANARITY	eee	0.08			
LEAD OFFSET	bbb	0.1			
EXPOSED PAD OFFSET	fff	0.1			



PART MARKING

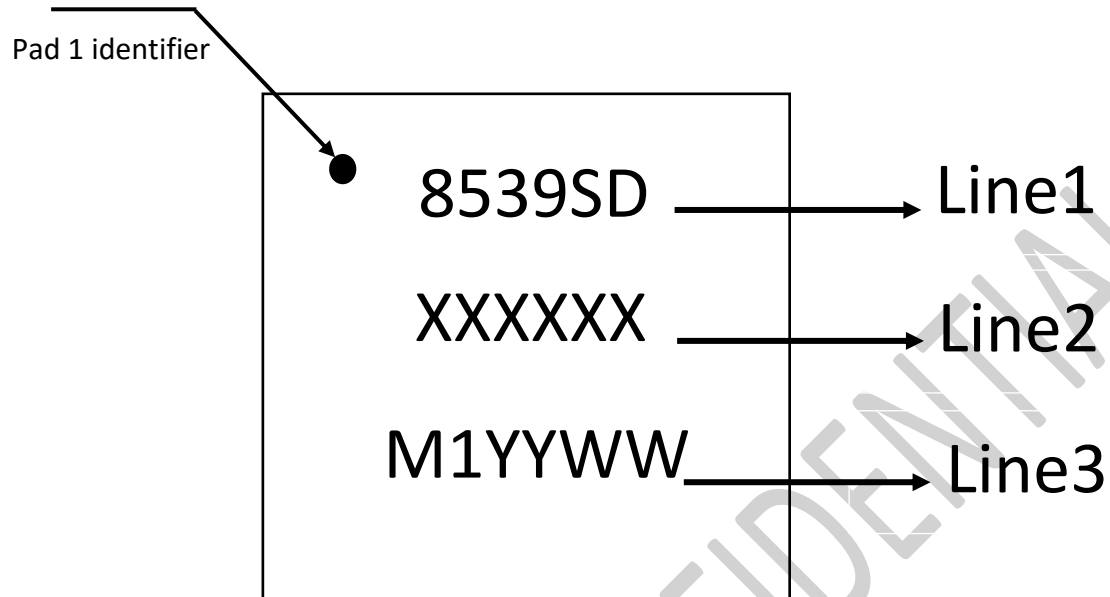

Line	Marking	Description
1	8539SD	Marking name
2	XXXXXX	Lot information
3	M1YYWW	M: Manufacturer Code 1: Part number postfix YYWW: YY year WW week