

THINKING ELECTRONIC INDUSTRIAL CO., LTD.

HEAD OFFICE: 8F-1, No.93, Ta-Shun 1st Rd., Kaohsiung, Taiwan

TEL: 886-7-5577660 FAX: 886-7-5570560

- KAOHSIUNG FACTORY: No.51, Kaifa Road, Nantze Export Processing Zone,
Kaohsiung City 81170, Taiwan
TEL: 886-7-9616668 FAX: 886-7-9616698
- KAOHSIUNG FACTORY 2:No. 2-2, Xinjian S. Rd., N.E.P.Z., Kaohsiung City 81170, Taiwan
TEL: 886-7-9630001 FAX: 886-7-3635113
- CHANGZHOU FACTORY: No.6,Longmen Road,Wujin National High&New-Tech Industrial
Development Zone,ChangZhou,JiangSu,China
TEL:86-519-86578999 FAX:86-519-86558643
- DONG GUAN FACTORY: Chiao-Tou Tsun, Sha-Tao Hsiang, Chang-An Town,
Dong-Guan City 523863, Guangdong, China
TEL:86-769-85542016 FAX:86-769-85546890
- YICHANG FACTORY: No. 283 Xiaoting Avenue, Xiaoting Dist., Yichang
City 443007, Hubei, China
TEL:86-717-6510010 FAX:86-717-6511430

**SPECIFICATION FOR APPROVAL**

CUSTOMER 立創電子

MODEL NO. NTSA3104

PART NO. NTSA3104HZ048(RoHS)

APPLICATION _____

CUSTOMER P/N _____

ISSUE DATE DEC.02.2020

REV. NO 1.0

REV. DATE _____

FOR CUSTOMER APPROVAL	CHECKED BY
	戶鋒
	APPROVED BY
	朱鳳美



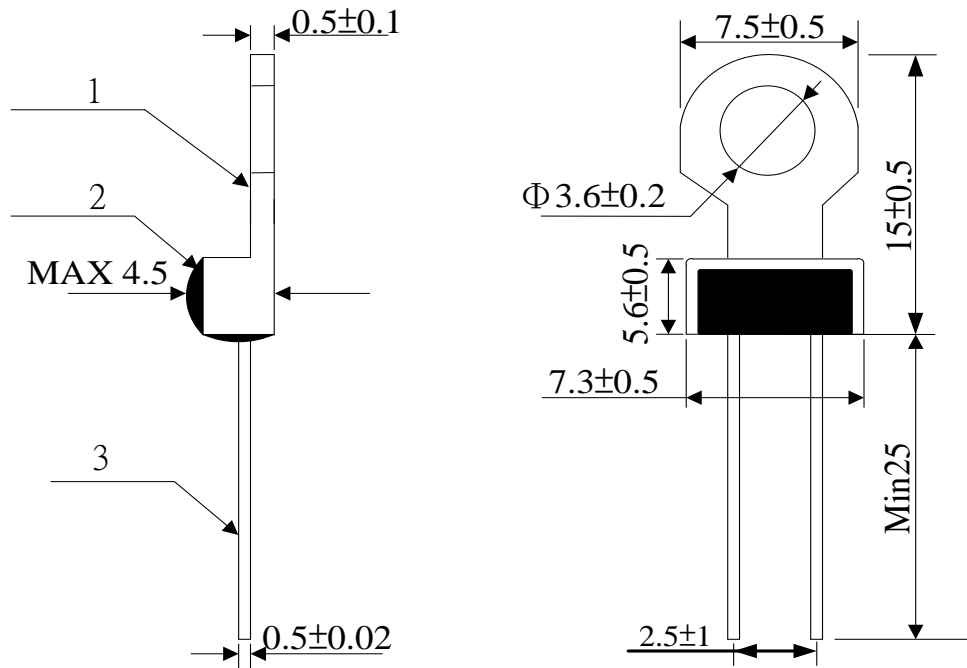

A. Material List

NO.	ITEM	DESCRIPTION
1	TERMINAL	B40320BL-2#
2	COATING RESIN	BLACK EPOXY
3	LEAD WIRE	$\Phi 0.5\text{mm}$ 鍍錫CP線
*	ELEMENT	NTC THERMISTOR

B. Electrical Characteristic

ITEM	VALUE
R25°C	100K Ω ±3%
B25/50	4050K±5%

Customer	立創電子
Customer P/N	
Thinking P/N	NTSA3104HZ048
Drawing NO.	SA1806037
Date	2018/9/20
Scale:	Tol: ±mm Unit: mm

1.0	2018/9/20	新圖檔制作		曹建暉	戶鋒	朱鳳美
Rev.	Date	Subjects of Change	ECN No	Designed by	Checked by	Approved by

THINKING ELECTRONIC INDUSTRIAL CO., LTD.

CUSTOMER: 立創電子

THINKING P/N:NTSA3104HZ048

NO	PART NAME	PART P/N	Q'TY	FLAMMABILITY SOLID BURNING CLASS	UL FILE NO
1	TERMINAL	B40320BL-2#	1	BRASS	
2	COATING RESIN	BLACK EPOXY			
3	LEAD WIRE	Φ0.5mm 鍍錫CP線	2		
*	ELEMENT	NTC THERMISTOR	1		
REMARK					

Approve 朱鳳美

Checked by: 戶鋒

Designed by: 曹建暉

Specification of NTC Thermistor for Temperature Measurement and Control

PART NO . NTSA3104HZ048

CUSTOMER P/N . _____

1. Electrical characteristics

	Parameter	Symbol	Test Conditions	Min.	Nor.	Max.	Unit.
a.	Resistance At 25°C	R ₂₅	T _a =25°C±0.05°C P _T ≤0.1mW	97.00	100.0	103.00	KΩ
b.	Resistance At 50°C	R ₅₀	T _a =50°C±0.05°C P _T ≤0.1mW	-----	31.927	-----	KΩ
c.	R ₂₅ /R ₅₀	K	-----	-----	3.132	-----	-----
d.	B Constant	B _{25/50}	(3853.887* LnK)	3848	4050	4253	K
e.	Thermal Dissipation Constant (in air)	δ	T _a =25°C (in air)	-----	Approx.5	-----	mW/°C
f.	Thermal Time Constant (in water)	τ	25°C→85°C T ₁ =25+(85-25)*63.2%=62.92°C	-----	Approx30	-----	Sec
g.	Hi-Pot Test	-----	1000V AC 1 sec	-----	-----	10	mA

2.Maximun Ratings

	Parameter	Specification	Unit
a.	Operation Temperature Range	-40 ----- +125	°C
b.	Max' power Dissipation at 25°C	150	mW

Max. Power Dissipation Derating Curve

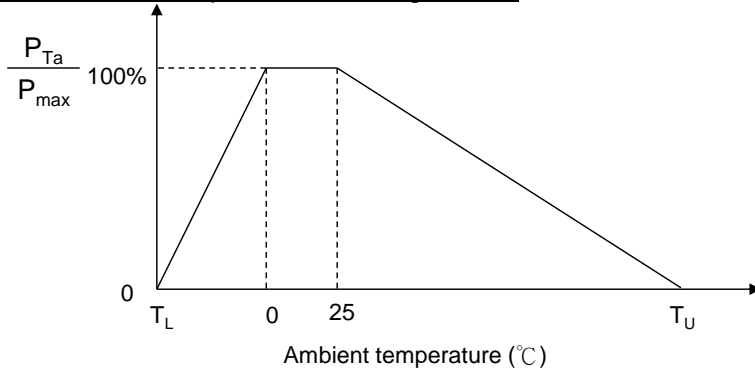

Note: T_L = Minimum Temp. of Operating Temp. Range (°C)

T_U = Maximum Temp. of Operating Temp. Range (°C)

3. Reliability Test

Item	Test Conditions	Variable
Temp. cycle test	-40 °C X 30min → +25 °C X 5 min X 10Cycles +125°C X 30min → +25 °C X 5 min	Within ± 5 %
Humidity test	40°C 95 % RH X 1000 HRS	Within ± 5 %

Install and use

1. Use this product within the specified temperature range.
2. Higher temperature may cause deterioration of the characteristics or the material quality of this product.
3. Do not melt the solder in resin head, when you solder this product. If you melt the solder in resin head, it has possibility that the break of wire, short and insulation damage.
4. Do not touch the resin head directly by solder iron. It may cause the melt of solder in resin head.
5. At least away from resin head 10mm above when lead dividing.
6. In case you cut the lead wire of this product less than 10mm from resin head, the heat of melted solder at lead wire edge is propagated easily to the resin head along the lead wire.
7. Radius of lead bending should be more than 1mm when lead bending.
Holding element by side lead wire is recommended when lead wire is bent or cut.
8. Do not apply an excessive force to the lead. Otherwise, it may cause junction between lead and element to break or crack.
9. The ceramic element of this product is fragile, and care must be taken not to load an excessive press-force or not to give a shock at handling. Such forces may cause cracking or chipping.
10. If you mold by resin this product, please evaluate the quality of this product before you use it.

Warehouse Storage Conditions of Products

To keep solderability of product from declining, the following storage condition is recommended.

1. Storage condition:

Temperature -10°C to +40°C

Humidity less than 75%RH (not dewing condition)

2. Storage term:

Use this product within 1 year after delivery by first-in and first-out stocking system.

3. Handling after unpacking:

After unpacking, reseal product promptly or store it in a sealed container with a drying agent.

4. Storage place:

Do not store this product in corrosive gas (Sulfuric acid gas, Chlorine gas, etc.) or in direct sunlight.

Warn and note item

This product is designed for application in an ordinary environment (normal room temperature, humidity and atmospheric pressure).

Do not use under the following conditions because all of these factors can deteriorate the product characteristics or cause failures and burn-out.

1. Corrosive gas or deoxidizing gas (Chlorine gas, Hydrogen sulfide gas, Ammonia gas, Sulfuric acid gas, Nitric oxide gas, etc.)
2. Volatile or flammable gas
3. Dusty conditions
4. Under vacuum, or under high or low pressure
5. Wet or humid locations; soak in the liquid or wash with liquid
6. Places with salt water, oils, chemical liquids or organic solvents and do not use directly with quick-drying glue.
7. Strong vibrations
8. Other places where similar hazardous conditions exist
9. Be sure to provide an appropriate fail-safe function on your product to prevent secondary damages that may be caused by the abnormal function or the failure of our product.

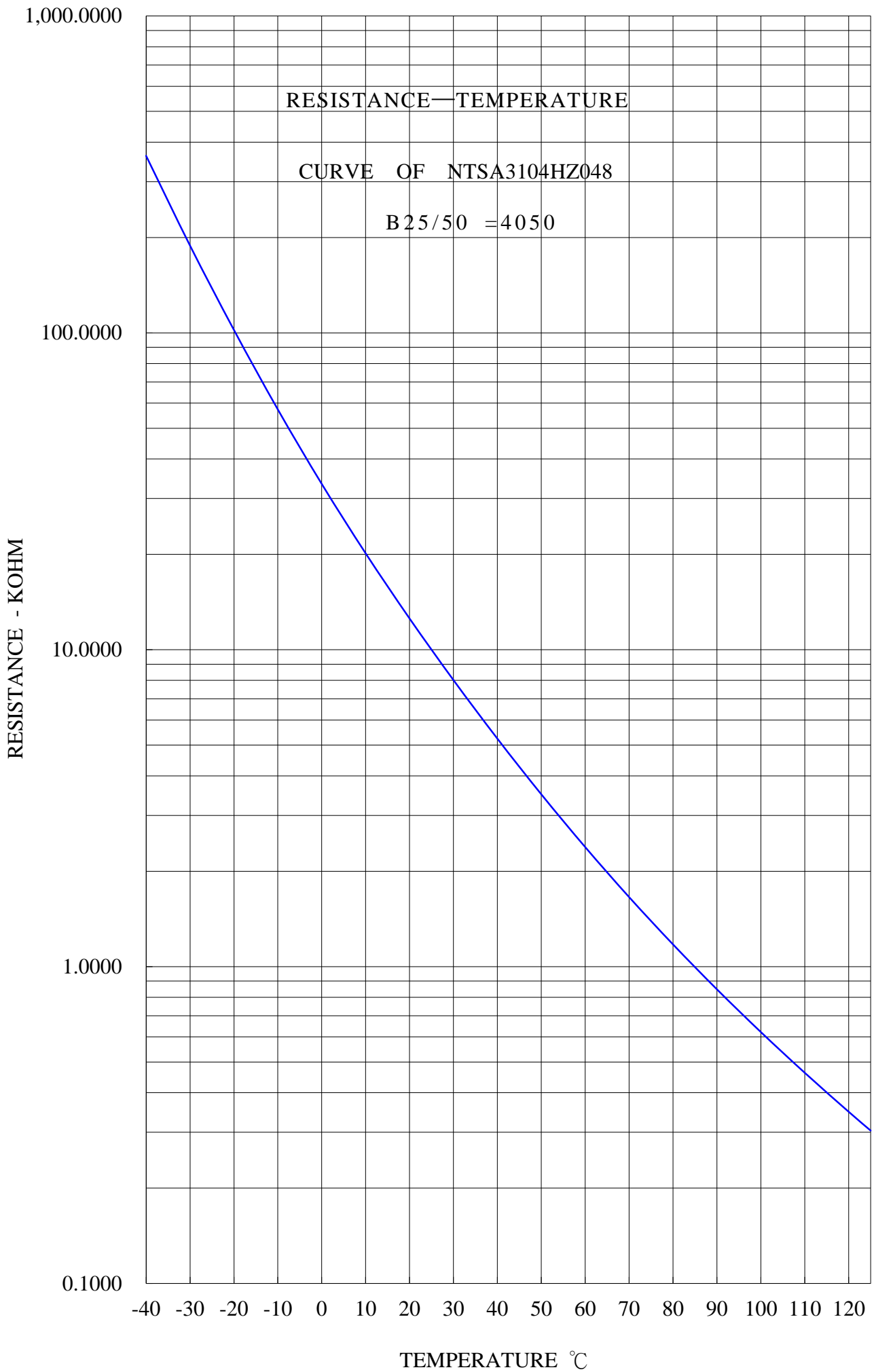

R - T Table

Part No. : NTSA3104HZ048

R25=100KΩ ±3%

B25/50 = 4050 K ± 5%

Temperature (°C)	Rmax. (KΩ)	Rnor. (KΩ)	Rmin. (KΩ)	Temperature Tol. (°C)	
-40	3700.61	3029.48	2477.83	-3.64	3.24
-39	3482.65	2859.30	2345.41	-3.66	3.24
-38	3279.89	2700.53	2221.51	-3.65	3.21
-37	3089.69	2551.18	2104.629	-3.61	3.16
-36	2910.32	2409.92	1993.770	-3.54	3.11
-35	2740.63	2275.91	1888.295	-3.47	3.04
-34	2579.88	2148.60	1787.800	-3.39	2.98
-33	2427.56	2027.61	1692.025	-3.31	2.92
-32	2283.32	1912.704	1600.800	-3.23	2.86
-31	2146.89	1803.698	1514.005	-3.15	2.81
-30	2018.01	1700.432	1431.538	-3.08	2.75
-29	1896.473	1602.751	1353.302	-3.01	2.70
-28	1782.021	1510.496	1279.191	-2.94	2.66
-27	1674.404	1423.492	1209.091	-2.88	2.62
-26	1573.346	1341.550	1142.874	-2.83	2.58
-25	1478.561	1264.465	1080.396	-2.78	2.54
-24	1389.747	1192.022	1021.508	-2.73	2.51
-23	1306.595	1123.998	966.049	-2.68	2.47
-22	1228.793	1060.164	913.852	-2.64	2.44
-21	1156.030	1000.289	864.751	-2.60	2.41
-20	1087.999	944.146	818.576	-2.56	2.39
-19	1024.401	891.510	775.161	-2.52	2.36
-18	964.946	842.163	734.341	-2.49	2.33
-17	909.358	795.893	695.959	-2.45	2.30
-16	857.373	752.501	659.863	-2.42	2.28
-15	808.741	711.795	625.905	-2.38	2.25
-14	763.229	673.593	593.950	-2.35	2.22
-13	720.616	637.727	563.864	-2.31	2.19
-12	680.696	604.036	535.527	-2.28	2.16
-11	643.278	572.371	508.822	-2.24	2.13
-10	608.185	542.594	483.641	-2.20	2.10
-9	575.253	514.576	459.884	-2.17	2.07
-8	544.329	488.196	437.458	-2.13	2.04
-7	515.272	463.345	416.276	-2.09	2.01
-6	487.954	439.919	396.256	-2.05	1.98
-5	462.254	417.824	377.325	-2.01	1.94
-4	438.061	396.972	359.413	-1.97	1.91
-3	415.276	377.282	342.456	-1.93	1.87
-2	393.802	358.679	326.394	-1.89	1.84
-1	373.555	341.094	311.173	-1.85	1.80
0	354.454	324.463	296.742	-1.80	1.76
1	336.426	308.727	283.052	-1.76	1.72
2	319.403	293.830	270.062	-1.72	1.68
3	303.320	279.723	257.729	-1.67	1.65
4	288.121	266.358	246.016	-1.63	1.61
5	273.752	253.691	234.888	-1.58	1.57
6	260.161	241.681	224.3118	-1.54	1.52

7	247.302	230.291	214.2570	-1.49	1.48
8	235.133	219.486	204.6950	-1.45	1.44
9	223.612	209.2313	195.5992	-1.40	1.40
10	212.702	199.4977	186.9445	-1.36	1.36
11	202.368	190.2560	178.7076	-1.31	1.32
12	192.5773	181.4791	170.8665	-1.26	1.27
13	183.2987	173.1418	163.4006	-1.22	1.23
14	174.5035	165.2204	156.2904	-1.17	1.19
15	166.1649	157.6926	149.5177	-1.13	1.14
16	158.2575	150.5375	143.0653	-1.08	1.10
17	150.7575	143.7353	136.9169	-1.03	1.05
18	143.6426	137.2675	131.0572	-0.99	1.01
19	136.8917	131.1164	125.4718	-0.94	0.96
20	130.4852	125.2657	120.1469	-0.89	0.92
21	124.4042	119.6997	115.0695	-0.85	0.87
22	118.6313	114.4037	110.2275	-0.80	0.83
23	113.1499	109.3638	105.6091	-0.75	0.78
24	107.9444	104.5667	101.2035	-0.70	0.74
25	103.0000	100.0000	97.0000	-0.66	0.69
26	98.7408	95.6520	92.5764	-0.71	0.74
27	94.6758	91.5114	88.3733	-0.76	0.80
28	90.7955	87.5678	84.3788	-0.82	0.85
29	87.0911	83.8111	80.5821	-0.87	0.90
30	83.5539	80.2319	76.9726	-0.93	0.96
31	80.1759	76.8211	73.5405	-0.98	1.01
32	76.9493	73.5703	70.2764	-1.04	1.06
33	73.8668	70.4714	67.1715	-1.10	1.12
34	70.9216	67.5168	64.2176	-1.15	1.17
35	68.1069	64.6992	61.4067	-1.21	1.23
36	65.4166	62.0118	58.7313	-1.27	1.28
37	62.8446	59.4481	56.1845	-1.32	1.33
38	60.3854	57.0019	53.7595	-1.38	1.39
39	58.0335	54.6674	51.4501	-1.44	1.44
40	55.7839	52.4390	49.2503	-1.50	1.50
41	53.6316	50.3115	47.1544	-1.56	1.55
42	51.5722	48.2799	45.1572	-1.62	1.61
43	49.6011	46.3396	43.2535	-1.68	1.66
44	47.7143	44.4859	41.4386	-1.74	1.72
45	45.9078	42.7148	39.7081	-1.80	1.78
46	44.1778	41.0221	38.0575	-1.86	1.83
47	42.5208	39.4041	36.4829	-1.93	1.89
48	40.9333	37.8571	34.9805	-1.99	1.94
49	39.4122	36.3777	33.5466	-2.05	2.00
50	37.9544	34.9627	32.1779	-2.11	2.06
51	36.5570	33.6091	30.8710	-2.18	2.11
52	35.2172	32.3137	29.6229	-2.24	2.17
53	33.9324	31.0740	28.4308	-2.31	2.23
54	32.7000	29.8872	27.2918	-2.37	2.28
55	31.5178	28.7509	26.2033	-2.44	2.34
56	30.3834	27.6627	25.1629	-2.50	2.40
57	29.2948	26.6204	24.1683	-2.57	2.46
58	28.2498	25.6217	23.2172	-2.63	2.51
59	27.2465	24.6648	22.30761	-2.70	2.57

60	26.2831	23.7476	21.43744	-2.76	2.63
61	25.3578	22.8684	20.60486	-2.83	2.69
62	24.4690	22.0254	19.80808	-2.90	2.74
63	23.6150	21.21701	19.04540	-2.97	2.80
64	22.7943	20.44160	18.31523	-3.03	2.86
65	22.0055	19.69770	17.61603	-3.10	2.92
66	21.2473	18.98392	16.94638	-3.17	2.97
67	20.5183	18.29890	16.30489	-3.24	3.03
68	19.81723	17.64137	15.69028	-3.31	3.09
69	19.14296	17.01012	15.10130	-3.38	3.15
70	18.49435	16.40398	14.53679	-3.45	3.21
71	17.87031	15.82187	13.99563	-3.52	3.27
72	17.26982	15.26273	13.47676	-3.59	3.32
73	16.69190	14.72557	12.97919	-3.66	3.38
74	16.13562	14.20945	12.50195	-3.73	3.44
75	15.60007	13.71345	12.04414	-3.80	3.50
76	15.08442	13.23672	11.60489	-3.88	3.56
77	14.58785	12.77844	11.18339	-3.95	3.62
78	14.10958	12.33783	10.77885	-4.02	3.68
79	13.64888	11.91415	10.39054	-4.09	3.74
80	13.20504	11.50668	10.01773	-4.17	3.80
81	12.77738	11.11475	9.65976	-4.24	3.86
82	12.36526	10.73771	9.31599	-4.32	3.92
83	11.96805	10.37494	8.98580	-4.39	3.98
84	11.58518	10.02586	8.66861	-4.47	4.04
85	11.21607	9.68991	8.36387	-4.54	4.10
86	10.86019	9.36654	8.07105	-4.62	4.16
87	10.51702	9.05525	7.78963	-4.70	4.22
88	10.18606	8.75554	7.51915	-4.77	4.28
89	9.86684	8.46696	7.25914	-4.85	4.35
90	9.55891	8.18904	7.00917	-4.93	4.41
91	9.26184	7.92137	6.76880	-5.01	4.47
92	8.97521	7.66353	6.53765	-5.09	4.53
93	8.69862	7.41513	6.31534	-5.17	4.60
94	8.43168	7.17580	6.10149	-5.25	4.66
95	8.17404	6.94518	5.89576	-5.33	4.72
96	7.92534	6.72293	5.69782	-5.41	4.79
97	7.68525	6.50872	5.50734	-5.49	4.85
98	7.45344	6.30223	5.32403	-5.58	4.91
99	7.22960	6.10316	5.14760	-5.66	4.98
100	7.01344	5.91123	4.97775	-5.74	5.04
101	6.80467	5.72615	4.81424	-5.83	5.11
102	6.60302	5.54767	4.65681	-5.91	5.18
103	6.40822	5.37553	4.50520	-6.00	5.24
104	6.22002	5.20948	4.35919	-6.09	5.31
105	6.03818	5.04929	4.21856	-6.17	5.38
106	5.86247	4.89474	4.08308	-6.26	5.44
107	5.69266	4.74562	3.95257	-6.35	5.51
108	5.52854	4.60171	3.82681	-6.44	5.58
109	5.36990	4.46282	3.70562	-6.53	5.65
110	5.21654	4.32876	3.58883	-6.62	5.72
111	5.06827	4.19934	3.47626	-6.71	5.79
112	4.92491	4.07440	3.36774	-6.81	5.86
113	4.78628	3.95377	3.26312	-6.90	5.93
114	4.65221	3.83727	3.16225	-7.00	6.00

115	4.52253	3.72477	3.06497	-7.09	6.07
116	4.39710	3.61611	2.97115	-7.19	6.14
117	4.27576	3.51114	2.88066	-7.28	6.22
118	4.15836	3.40974	2.79337	-7.38	6.29
119	4.04476	3.31176	2.70915	-7.48	6.37
120	3.93484	3.21709	2.62789	-7.58	6.44
121	3.82845	3.12559	2.54947	-7.68	6.51
122	3.72548	3.03716	2.47379	-7.78	6.59
123	3.62580	2.95168	2.40074	-7.89	6.67
124	3.52930	2.86905	2.33022	-7.99	6.74
125	3.43586	2.78915	2.26213	-8.09	6.82