



MXD8628

0.1-3.0GHz SP2T Switch

This document contains information that is confidential and proprietary to Maxscend Technologies Inc. (Maxscend) and may not be reproduced in any form without express written consent of Maxscend. No transfer or licensing of technology is implied by this document.

General Description

The MXD8628 is a CMOS silicon-on-insulator (SOI), single-pole, double-throw (SP2T) transmitting and receiving switch. The high linearity performance and low insertion loss makes the device an ideal choice for GSM/WCDMA/LTE handset and data card applications.

The MXD8628 SP2T switch is provided in a compact LGA 9-pin 1.15mm x 1.15mm x 0.45mm package. A functional block diagram is shown in Figure 1. The pin configuration and package are shown in Figure 2. Signal pin assignments and functional pin descriptions are provided in Table 1.

Applications

- GSM/WCDMA/LTE receive and transmit
- 802.11b/g/n WLANs

Features

- Broadband frequency range: 0.1 to 3.0 GHz
- Low insertion: 0.50 dB @ 2.7 GHz
- High isolation: 25 dB up to 2.7 GHz
- P0.1dB of 36dBm
- No external DC blocking capacitors required
- Positive low voltage control: VC = 1.6 to 3.00 V, VDD = 2.5 to 3.0 V
- Small, LGA (9-pin, 1.15mm x 1.15mm x 0.45mm) package

Functional Block Diagram and Pin Function

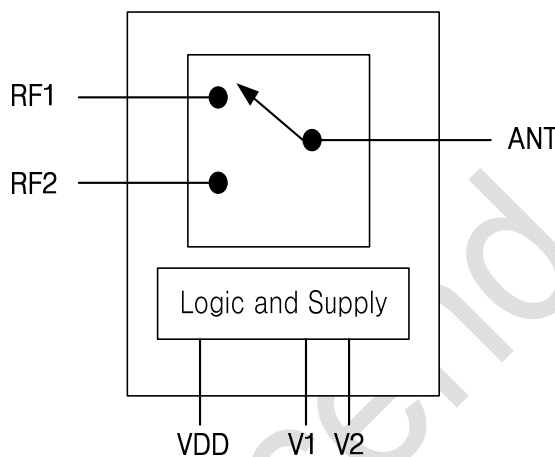

Figure 1 Functional Block Diagram

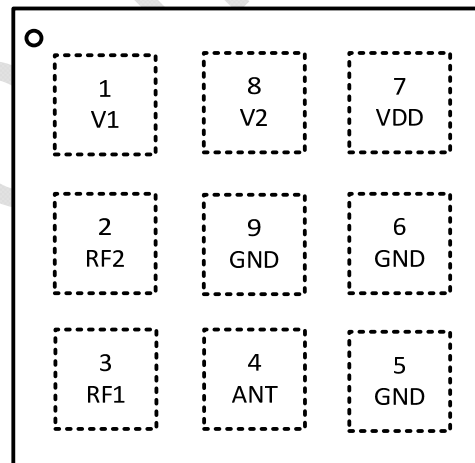
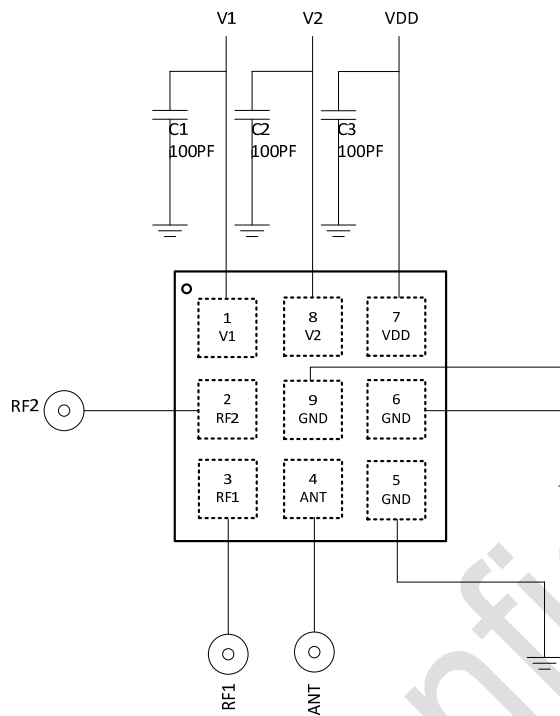

Figure 2 Pin-out (Top View)

Application Circuit

Figure 3 MXD8628 Application Circuit
Table 1. Pin Description

Pin No.	Name	Description	Pin No.	Name	Description
1	V1	Control Pin 1	6	GND	Ground
2	RF2	RF-Port 2	7	VDD	Power Supply
3	RF1	RF-Port 1	8	V2	Control Pin 2
4	ANT	Antenna	9	GND	Ground
5	GND	Ground			

Truth Table
Table 2.

V1	V2	Active Path
0	0	OFF
1	0	ANT to RF1
1	1	ANT to RF2

Note: "1" = 1.0 V to 3.00 V. "0" = 0 V to +0.3 V.

Recommended Operation Range
Table 3.

Parameters	Symbol	Min	Typ	Max	Units
Operation Frequency	f1	0.1	-	3.0	GHz
Power supply	V _{DD}	2.5	2.8	3.0	V
Switch Control Voltage High	V _{CTL_H}	1.6	1.8	3.0	V
Switch Control Voltage Low	V _{CTL_L}	0	0	0.3	V

Specifications
Table 4. Electrical Specifications

Parameter	Symbol	Specification			Units	Test Condition
		Min.	Typical	Max.		
DC Specifications						
Control voltage:						
Low	V_{CTL_L}	0	+1.8	0.3	V	
High	V_{CTL_H}	1.60		3.00	V	
Supply voltage	V_{DD}	2.5	2.8	3.0	V	
Supply current	IDD		40	60	uA	VDD = 2.8 V
Control current	Ictl		1		uA	VC= 1.8 V
RF Specifications						
Insertion loss	IL		0.30	0.40	dB	0.1 to 1.0 GHz
			0.40	0.50	dB	1.0 to 2.2 GHz
			0.50	0.60	dB	2.2 to 3.0 GHz
Isolation	ISO	30	35		dB	0.1 to 1.0 GHz
		25	30		dB	1.0 to 2.2 GHz
		20	25		dB	2.2 to 3.0 GHz
Return loss	S11		15		dB	0.1 to 3.0 GHz
3rd Order Input Intercept Point	IIP3	+60	+70		dBm	0.1 to 3.0 GHz, $\Delta F = 1$ MHz, PIN = +20 dBm/tone
Input 0.1 dB compression point	P0.1dB		+36		dBm	0.1 to 3.0 GHz, ANT to RF1 and RF2
2nd harmonic	2fo		+83		dBc	0.1~3GHz, PIN = +26 dBm
3rd harmonic	3fo		+70		dBc	0.1~3GHz, PIN = +26 dBm
Switching on time			2		us	50% VCTL to 10/90% RF
Switching off time			2		us	50% VCTL to 90/10% RF
Startup time			5		us	Shutdown state to any RF switch state

Absolute Maximum Ratings
Table 5. Maximum ratings

Parameters	Symbol	Minimum	Maximum	Units
Supply voltage	V_{DD}	+2.5	+3.0	V
Digital control voltage	V_{CTL}	0	+3.0	V
RF input power	P_{IN}		+36	dBm
Operating temperature	T_{OP}	-30	+85	°C
Storage temperature	T_{STG}	-55	+150	°C
Electrostatic discharge: Human Body Model (HBM), Class 1C Machine Model (MM), Class A	ESD		1000	V
			100	V

Note: Exposure to maximum rating conditions for extended periods may reduce device reliability. There is no damage to device with only one parameter set at the limit and all other parameters set at or below their nominal value. Exceeding any of the limits listed here may result in permanent damage to the device.

Package Outline Dimension

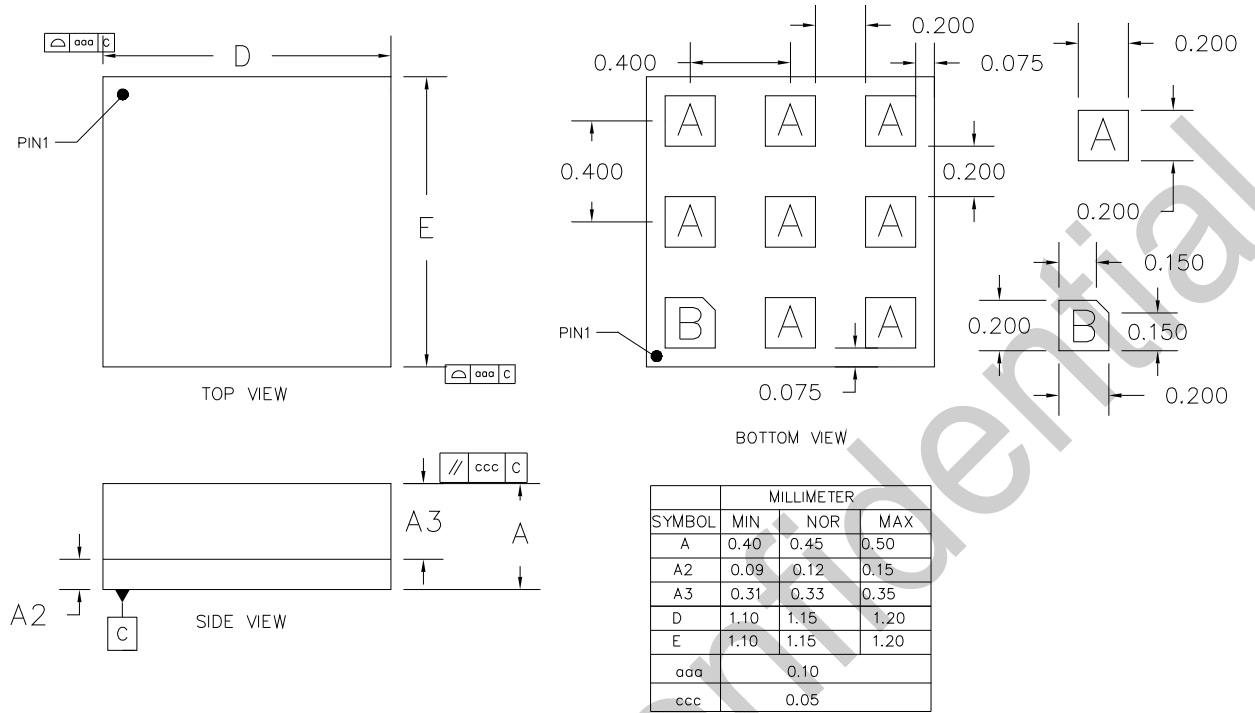

Figure 4. Package outline dimension

Reflow Chart

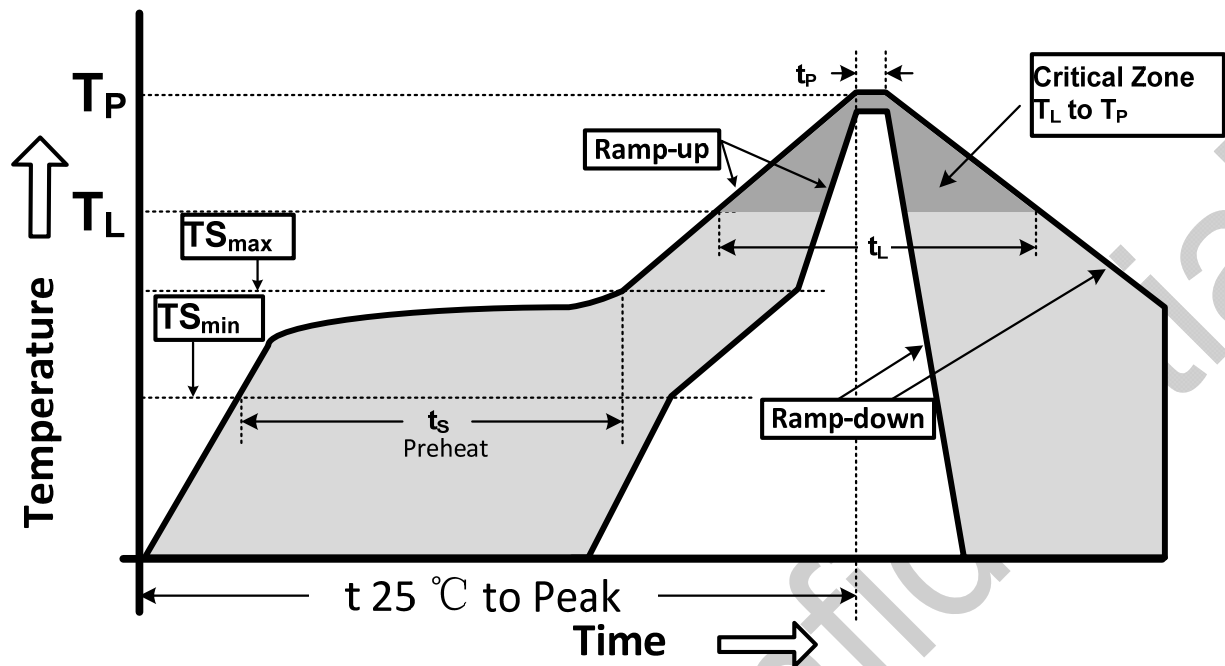

Figure 5. Recommended Lead-Free Reflow Profile

Table 6 Reflow condition

Profile Parameter	Lead-Free Assembly, Convection, IR/Convection
Ramp-up rate (T_S_{max} to T_P)	3°C/second max.
Preheat temperature (T_S_{min} to T_S_{max})	150°C to 200°C
Preheat time (t_s)	60 - 180 seconds
Time above T_L , 217°C (t_L)	60 - 150 seconds
Peak temperature (T_P)	260°C
Time within 5°C of peak temperature (t_p)	20 - 40 seconds
Ramp-down rate	6°C/second max.
Time 25°C to peak temperature	8 minutes max.

ESD Sensitivity

Integrated circuits are ESD sensitive and can be damaged by static electric charge. Proper ESD protection techniques should be used when handling these devices.

RoHS Compliant

This product does not contain lead, mercury, cadmium, hexavalent chromium, polybrominated biphenyls (PBB) and polybrominated diphenyl ethers (PBDE), and are considered RoHS compliant.